

MINISTRY OF EDUCATION AND SCIENCE OF UKRAINE

Zaporizhzhya national technical university

METHODICAL GUIDES

for laboratory work №7 on course

**“FUNDAMENTALS OF METROLOGY
AND ELECTRICAL MEASUREMENT ”**

students towards the specialty
141 – Electric Power Engineering, Electrical Engineering and
Electromechanics
of all forms of learning

2018

Methodical guides for laboratory work №7 on course "Fundamentals of metrology and electrical measurement" students towards the specialty 141 – Electric Power Engineering, Electrical Engineering and Electromechanics of all forms of learning. / Set. O. S. Nazarova. – Zaporizhzhia: ZNTU, 2018. – 15 p.

Compiler: O. S. Nazarova, docent c.t.n.

Reviewer: V. V. Osadchiy, docent c.t.n.

Responsible for the issue: V. I. Bondarenko, docent c.t.n.

Approved
chair meeting EPA
protocol number 08 on 25.04.2018 p.

Approved
chair meeting EMC ETF
protocol number 09 on 26. 04.2018 p.

CONTENTS

Preface	4
Laboratory work №7	
Measurement of electrical quantities by a digital oscilloscope	5
1 Short theoretical information	5
2 Instruments and equipment	11
3 The task.....	11
4 Contents of the report of the laboratory work.....	13
5 Control questions.....	14
References.....	14

PREFACE

Methodical instructions contain descriptions of the laboratory work №7 on course “Fundamentals of metrology and electrical measurement” in accordance with the curriculum specialties Bachelor's Degree 141 – Electric Power Engineering, Electrical Engineering and Electromechanics and recommendations for their implementation.

Laboratory work containing short theoretical information under the theme of work, objectives, recommendations for their implementation and test questions for better learning and verifying the student knowledges and skills.

For students of specialty 141 – Electric Power Engineering, Electrical Engineering and Electromechanics of all forms of learning.

Laboratory work №7

Measurement of electrical quantities by a digital oscilloscope.

Aim of work: the study of the structure, the principle of the digital oscilloscope OWON PSD 5022S and get the skills to measure electrical quantities.

1 SHORT THEORETICAL INFORMATION

The oscilloscope OWON PSD 5022S is intended for research of electric signals by their visual observation on a liquid crystal display and measurement of their amplitude and time parameters. The oscilloscope can be used for laboratory and shop conditions, as well as for research and repair work.

General Information: record length of 5,000 points for each channel; reading-out with the cursor; twenty automatic measurement functions; autoscale function; color liquid crystal display of high resolution and high contrast; storage and recall waveforms; automatic setting function provided capable of fast setting; multiple-waveform calculation function; built-in FFT function; perform detecting the average and peak values of the waveform; digital real-time oscilloscope; edge, video and Alternating triggering function; RS232 or USB communication ports; different continuous displaying time.

Warning! In order to avoid suffering from the electric shock, please keep your finger behind the safety guard ring of the probe body during the operation. In order to protect you from suffering from the electric shock during your using the probe, do not touch the metal part of the probe tip when the probe is connected to the power supply. Before making any measurements, please connect the probe to the instrument and connect the ground terminal to the earth.

Before starting measurements, connect the device to a 220V power supply. The oscilloscope is activated by the "POWER" button on the upper part of the device housing (Fig. 1.1).

The instrument carries out all self-check items and shows the prompt "Press any Key Enter the Operating Mode".

Table 1.1 lists the controls and indications for the front panel of the oscilloscope (Fig.1.2).

Table 1.1

Marking	Function
1	Function Buttons
2	Adjustment Menu Selection (F1 – F5)
3	Connector for compensation of the probe (Fig. 1.3)
4	Vertical Control (5 V...5mV)
5	Connector (CH1, CH2)
6	Horizontal Control (Position)
7	Trigger Control



Figure 1.3 – Connection of the Probe

Press the “UTILITY” button to get access to the “FUNCTION” menu and push down F2 the menu selection button to call out the function “Recall Factory”. The default attenuation coefficient set value of the probe in the menu is 10X, shown as Fig.1.4.

The list of elements for setting the measuring channel is shown in Table 1.2.

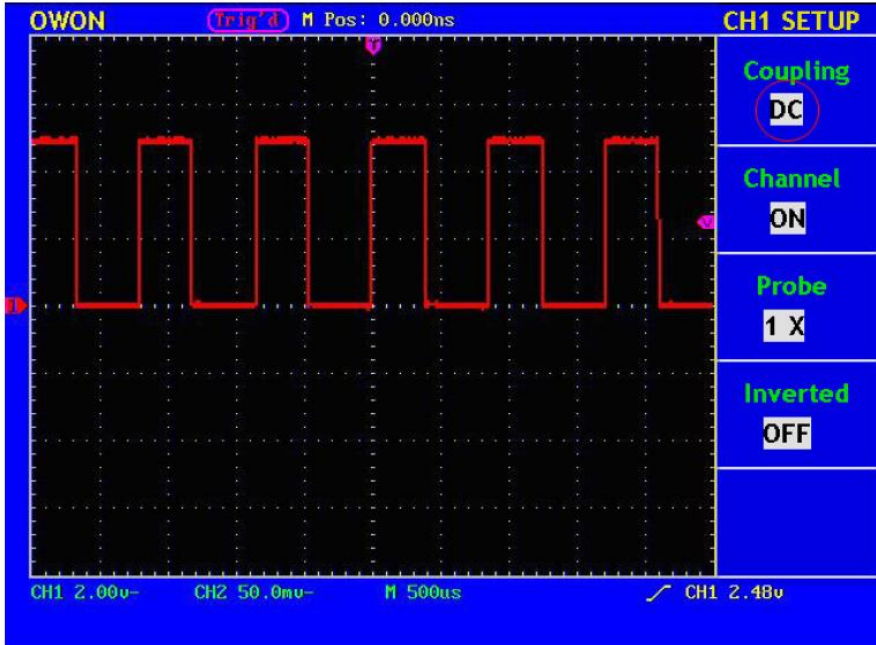

Figure 1.4 – DC Coupling Oscillogram

Table 1.2

Function Menu	Setting	Description
Coupling	AC	Block the DC component in the input signal.
	DC	Unblock the AC and DC components in the input signal.
Channel	OFF	Close the measurement channel.
	ON	Open the measuring channel.
Probe	1X	Choose one according to the probe attenuation factor to make the vertical scale reading accurate.
	10X	
	100X	
	1000X	
Inverted	OFF	The wave form is displayed normally.
	ON	Initiate the wave form inverted function.

Setting Channel Coupling

Taking the Channel 1 for example, the measured signal is a square wave signal containing the direct current bias. The operation steps are shown as below: press the **CH1 MENU** button and call out the **CH1 SETUP** menu.

Press the **F1** menu selection button and select the Coupling item as “AC” to set the channel coupling as ac mode, under which the direct current component in the signal will be blocked. Then, press the **F1** menu selection button again and select the Coupling item as “DC”, setting the channel coupling as DC mode, under which both dc and accomponents in the signal will be unblocked.

Press the **F2** menu selection button and select the Channel as **OFF**, with Channel 1 switched off. Press **F2** menu selection button again, select the channel as **ON**, with Channel 1 is switched on.

Press the **F3** menu selection button and select 1X for the probe. To display the signal oscilloscope on the correct scale, you must adjust the relief factor of the probe in the measuring channel settings menu. When using a probe with a 1: 1 loosening, it is necessary to select a 1X installation.

Wave form inverted: the displayed signal is turned 180 degrees against the phase of the earth potential. Press the **F4** menu selection button and select **ON** in the **Inverted**. The wave form inverted function is initiated. Press the **F4** menu selection button again and select OFF for **Inverted** item. The function of wave form inverted is closed off.

Perform Mathematical Manipulation Function (Table 1.3).

Press the **MATH MENU** button and call out the **WAVE MATH** menu. Press the **F3** menu selection button and choose **CH1+CH2**. The green calculated wave form M is displayed in the screen; press the **F3** menu selection button again, the wave form M is closed off (Fig. 1.5).

Table 1.3

Setting	Description
CH1-CH2	Subtract the Channel 2 wave form from the Channel 1 wave form.
CH2-CH1	Subtract the Channel 1 wave form from the Channel 2 wave form.
CH1+CH2	Add the Channel 1 wave form to the Channel 2.

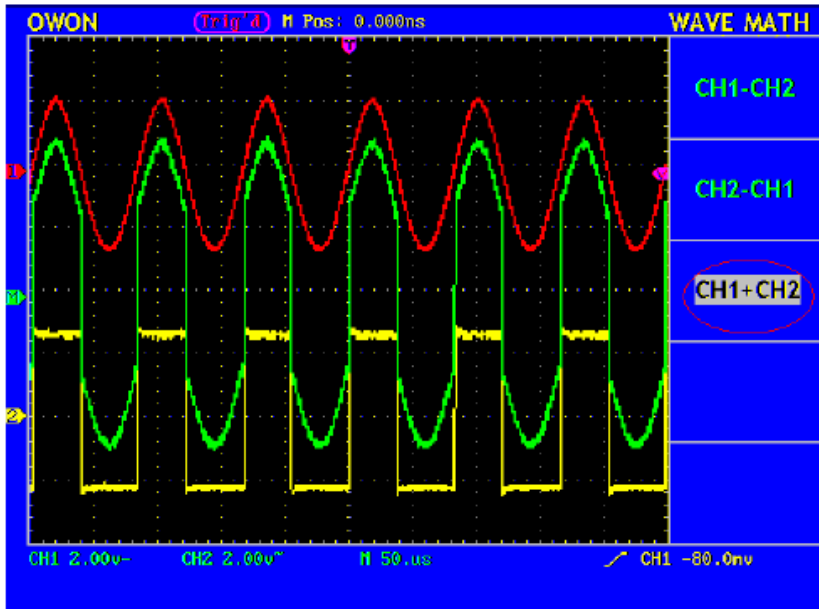

Figure 1.5 – Wave Form resulted from CH1 +CH2 Mathematical Manipulation

The **.VERTICAL POSITION** knob is used to adjust the vertical positions of the wave forms of all Channels (including those resulted from the mathematical operation). The analytic resolution of this control knob changes with the vertical division.

The **VOLTS/DIV** knob is used to regulate the vertical resolution of the wave forms of all channels (including those obtained from the mathematical manipulation), which can determine the sensitivity of the vertical division with the sequence of 1—2—5. The vertical sensitivity goes up when the knob is rotated clockwise and goes down when the knob is rotated anticlockwise.

When the vertical position of the channel wave form is adjusted, the screen shows the information concerning the vertical position at the lower left corner **HORIZONTAL POSITION** knob: this knob is used to adjust the horizontal positions of all channels (include those obtained from the mathematical manipulation), the analytic resolution of which changes with the time base.

SEC/DIV knob: it is used to set the horizontal scale factor for setting the main time base or the window.

HORIZONTAL MENU button: with this button pushed down, the screen shows the operating menu

2 INSTRUMENTS AND EQUIPMENT

The list of devices and equipment is given in table 2.1

Table 2.1

Name of device, equipment	Type of device, equipment	Accuracy class	basic characteristics
Induction meter	CO-H446	2,5	$A=1200$; $U_H=220V$; $I_H=5...17A$
Ammeter	Э59	0,5	0-2,5-5,0 A
Milliammeter	Э34	1,0	0-70 mA
Voltmeter	Э-378	1,5	0-250 V
Laboratory autotransformer ЛАТФ	навальный		
phase responsive device	-	-	

3 THE TASK

Collect scheme (Fig. 3.1). After the switch to establish the nominal current $\cos\phi = 1$. To set $\cos\phi = 1$ rotate the shifter knob to the maximum evidence kilowatt hour meters.

At the instruction of the teacher, change the position of the knob of the controller.

According to the oscilloscope graphs of voltage and current signals, find out at which angle the voltage and current are shifted from each other, calculate the measured power according to the oscilloscope, compare the calculated power with the value measured by the watt meter.

Results of measurements and calculations write in table 3.1.

Voltage and current are shifted by phase at the angle ϕ (Fig. 3.2)

$$\phi = ((t_2 - t_1) \cdot 360^\circ) / T = (t_2 - t_1) \cdot 360^\circ \cdot f,$$

where T – period of measured signal, sec; $f = 1/T$ – frequency, Hz.

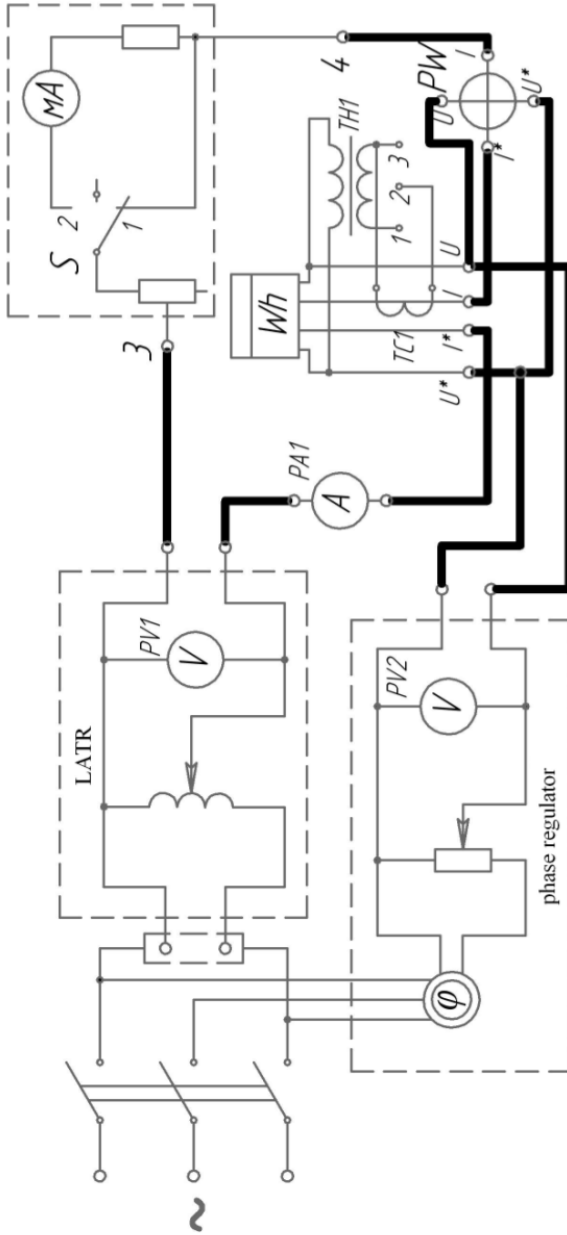

Figure 3.1 - Scheme of laboratory installation.

Table 3.1

Measured					Calculated				
I, A	U, V	P _w , Wt	Δt, sec	N, turn	φ, rad	i _m , A	u _m , V	p, Wt	P _{wh} , Wt

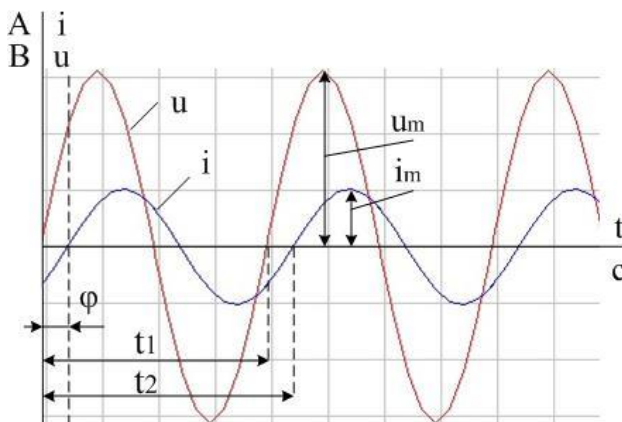

Figure 3.2 – Graphics of measured typical voltage and current signals

Instantaneous values of voltage, current and instantaneous power are determined by the relationships:

$$p = ui, \quad u = U_m \sin(\omega t), \quad i = I_m \sin(\omega t - \varphi).$$

Active power is determined from the ratio

$$P = UI \cos \varphi, \quad U = U_m / \sqrt{2}, \quad I = I_m / \sqrt{2}.$$

Power measured by the induction counter

$$P_{wh} = N / (A \cdot \Delta t),$$

where N - number of revolutions of the counter, turn; A - transfer number of the counter equal to the number of turns per unit of energy (1kWt h) and is indicated on its shield; Δt - time of implementation of N rotations of the disk of the counter, sec.

4 CONTENTS OF THE REPORT OF THE LABORATORY WORK

The contents of the laboratory work should contain the subject, the purpose of the laboratory work, the short theoretical information, filled in

tables 2.1 and 3.1, the scheme of the laboratory installation, photos of the screen of the oscilloscope, which contains images of the measured electric signals, an oscillogram pattern indicating the values used to calculate the measured power, calculations, conclusion.

5 CONTROL QUESTIONS

- 5.1 Explain the concept of quantization and sampling.
- 5.2 Bring a generalized block diagram of a digital meter.
- 5.3 Explain the concept of analog-digital conversion.
- 5.4 Basic metrological characteristics of ADCs and digital devices
- 5.5 Digital Meter Errors.
- 5.6 Explain the phenomenon of phase shift.
- 5.7 Explain the procedure for connecting and measuring a particular electric value with the digital oscilloscope OWON PSD 5022S.
- 5.8 Explain how to determine the measured value according to the data of the digital oscilloscope OWON PSD 5022S.
- 5.9 Explain how to change the horizontal and vertical position of measured signals.
- 5.10 Explain the sequence of actions for setting the measuring channel of the digital oscilloscope OWON PSD 5022S.
- 5.11 Name the mathematical operations of the digital oscilloscope OWON PSD 5022S.

REFERENCES

1. Portable Colour Digital Storage Oscilloscope OWON PDS Series. User Manual. - Режим доступу:
<http://www.saelig.com/downloads/pds5022s.pdf>
2. Основи метрології та електричних вимірювань: підручник : зать. МОНУ / В. В. Кухарчук, В. Ю. Кучерук, Є. Т. Володарський, В. В. Грабко. – Херсон : Олді-плюс, 2013. – 538 с.
3. Метрологія та вимірювальна техніка: підручник / Є. С. Поліщук, М. М. Дорожовець, В. О. Яцук та ін.; за ред. Є. С. Поліщука.- 2-ге вид., доп. та перероб. – Львів : Львівська політехніка, 2012. – 544 с.
4. Осадчий, В. В. Ідентифікація ступеня завантаження двохшвидкісного ліфта / В. В. Осадчий, О. С. Назарова, С. С. Шульженко // Електротехнічні та комп'ютерні системи. – 2018. –

№ 27(103).– С. 103-111.

DOI: <https://doi.org/10.15276/eltecs.27.103.2018.11>

5. Осадчий, В. В. Лабораторный стенд для исследования микропроцессорных систем управления двухмассовым электроприводом / В. В. Осадчий, Е. С. Назарова, В. В. Брылистый, Р. И. Савилов // Електротехнічні та комп'ютерні системи. – 2016. – № 22(98).– С. 33-38. <http://dx.doi.org/10.15276/eltecs.22.98.2016.05>

6. Назарова, Е. С. Особенности моделирования электромеханических систем с переменным моментом инерции / Е. С. Назарова, Р. А. Ефименко // Вісник НТУ «ХПІ». – 2017. – № 27(1249). – С. 71-74.

7. Осадчий, В. В. Исследование системы управления позиционным электроприводом с дискретным датчиком положения / В. В. Осадчий, Е. С. Назарова, В. В. Брылистый, Р. И. Савилов // Вісник НТУ «ХПІ». – 2017. – № 27(1249). – С. 146-149.

8. Новое в моделировании и исследовании электромеханических систем станов холодной прокатки : монографія / А. В. Садовой, Е. С. Назарова, В. И. Бондаренко, А. В. Пирожок; Запорізьк. нац. техніч. ун-т, Дніпродзерж. держ. теніч. ун-т – Запоріжжя: «Просвіта», 2014. – 144 с.

9. Осадчий, В. В. Лабораторный стенд для исследования алгоритмов микропроцессорных систем управления шаговыми двигателями / В. В. Осадчий, Е. С. Назарова, С. Ю. Тоболкин // Електромеханічні і енергозберігаючі системи. – 2014. – Вип. 2/(26). – С.102-108.

10. Осадчий, В. В. Исследование позиционного электропривода на основе шагового двигателя в микрошаговом режиме / В. В. Осадчий, Е. С. Назарова, С. Ю. Тоболкин // Електротехнічні та комп'ютерні системи. – 2015. – № 19(95). – С. 24-27. <http://dx.doi.org/10.15276/eltecs.19.95.2015.06>

11. Назарова, Е. С. Математическое моделирование электромеханических систем станов холодной прокатки / Е. С. Назарова // Технічна електродинаміка. – 2015. – Вип. 5 – С. 82-89.