

МІНІСТЕРСТВО ОСВІТИ І НАУКИ УКРАЇНИ
Запорізький національний технічний університет

**МЕТОДИЧНІ ВКАЗІВКИ
ДО ЛАБОРАТОРНОГО ПРАКТИКУМУ З ФІЗИКИ
РОЗДІЛ „КОЛИВАННЯ ТА ХВИЛІ”**

Для студентів інженерно-технічних спеціальностей
денної форми навчання
(англійською мовою)

2018

Методичні вказівки до лабораторного практикуму з фізики розділ „Коливання та хвилі”. Для студентів інженерно-технічних спеціальностей денної форми навчання (англійською мовою) / Укладач: С.П.Луцин. - Запоріжжя: ЗНТУ, 2018. - 66 с.

Укладач:
доцент кафедри фізики

С.П.Луцин

Рецензенти:
доцент кафедри фізики ЗНТУ
старший викладач кафедри іноземної мови

М.І. Правда
Т.О. Сокол

Затверджено на засіданні кафедри фізики.

Протокол № 6 від 11.05.2018 р.

Рекомендовано до видання НМК електротехнічного факультету.

Протокол № 10 від 31.05.2018 р.

Відповідальний за випуск С.П. Луцин, канд. фіз.-мат. наук, доцент.

CONTENTS

Introduction	5
1 Laboratory work № 41. Spring pendulum	6
1.1 Theory	6
1.2 Practical part	8
Control questions	10
2 Laboratory work № 42. Mathematical pendulum	11
2.1 Short theory	11
2.2 Experimental part	12
Control questions	13
3 Laboratory work № 43.1. Physical pendulum	14
3.1 Theoretical part	14
3.2 Work procedure	18
Control questions	20
4 Laboratory work № 43.2. Oscillation of peg	21
4.1 Theoretical part	21
4.2 Practical part	23
Control questions	24
5 Laboratory work № 43.3. Determination of the resulted length of physical pendulum	26
5.1 Theoretical part	26
5.2 Practical part	28
Control questions	29
6 Laboratory work № 43.4. Determination of the free fall acceleration with help of reversible pendulum	31
6.1 Experimental installation description	31
6.2 Theoretical part	32
6.3 Practical part	33
Control questions	35
7 Laboratory work № 43.5. Torsion pendulum	37
7.1 Theoretical part	38
7.2 Practical part	41
Control questions	43
8 Laboratory work № 43.6. Oscillation of hoop	45
8.1 Theoretical part	45
8.2 Practical part	47

Control questions	47
9 Laboratory work № 44. Mechanical free damped oscillations	49
9.1 Short theory	49
9.2 Experimental part	51
Control questions	53
10 Laboratory work № 45. Electromagnetic free damped oscillations	54
10.1 Short theory	54
10.2 Experimental part	57
Control questions	58
11 Laboratory work № 46. Resonance in oscillatory circuit	59
11.1 Experimental setting	59
11.2 Theoretical part	59
11.3 Experimental part	61
Control questions	63
12 Labor safety regulation №62 during working in physics laboratory.....	64
12.1 General provisions.....	64
12.2 Safety requirements before starting work.....	64
12.3 Safety requirements during laboratory work	64
12.4 Safety requirements after finishing the work.....	64
12.5 Safety requirements in case of emergencies.....	65
References.....	66

INTRODUCTION

Basic goal of the laboratory work manual on Physics is to enable students to learn important physical phenomena by experience. Laboratory work description does not try to give students a complete picture of the studied phenomena. Such presentation can only be achieved as a result of study of lectures and textbooks.

Large attention in the laboratory work manual on Physics for the students of technical professions is devoted to the handling of the measured results. Prior independent preparation, above all theoretical, is needed for successful completion of the work.

Every laboratory work is supposed to take two academic hours. Before the class a student must prepare a protocol of laboratory work and learn appropriate theoretical material.

During the class students do the necessary measurements, execute calculations and take the report to the conclusion. Measured results are discussed with a teacher and confirmed.

Fully designed report on laboratory work should be given to the teacher before the end of the class. It must include: title sheet, laboratory work number and name, list of devices and installations, purpose of work, drawing of the setting, calculation formulae, table of the measurement results and calculations, conclusions, as the result of the work. Graphs must be done on a millimeter`s paper.

If a student does not have time to support the laboratory work before the end of the class, he/she is allowed to design a report (graph) with the use of the computer programs (Excel, Origin) for the next class.

Laboratory work is considered done after the successful speech in support in front of a teacher (report explanation + mark for theoretical material).

Support of report: purpose of work + experimental method + conclusions.

Theoretical material: knowledge of the physical phenomena, which was studied in this laboratory work (laws, formulas).

1 LABORATORY WORK № 41 SPRING PENDULUM

Purpose of the work is to study dependence of period of oscillations on mass for a spring pendulum.

Task: to define acceleration of free falling; experimentally to check up the theoretical formula of period of the spring pendulum.

Devices and accessories: spring, set of weights, stopwatch, ruler.

1.1 Theory

Oscillations of a spring pendulum are acted upon by the elastic force

$$F = -k \cdot x, \quad (1.1)$$

where x is a deviation from state of stable equilibrium, k is a rigidity of the spring. The period of oscillations is

$$T = 2\pi \sqrt{\frac{m}{k}}, \quad (1.2)$$

where m is mass of the body fixed on the spring.

Spring pendulum (fig.1.1) it a body is suspended on a spring. At the leadingout of it from position of equilibrium of x_0 on distance of x there is force of elasticity F , which by Hook's law is evened $F = -kx$, where k is rigidity of spring. This force gives the acceleration

$$\frac{d^2x}{dt^2} = \frac{F}{m}, \quad \text{or} \quad \frac{d^2x}{dt^2} = -\frac{kx}{m}. \quad (1.3)$$

Equation (1.1) can be write down in such a way

$$\frac{d^2x}{dt^2} + \frac{kx}{m} = 0. \quad (1.4)$$

Designating $\frac{k}{m} = \omega_0^2$, get $\frac{d^2x}{dt^2} + \omega_0^2 x = 0$. (1.5)

Equation (1.3) is named **differential equation of undamped free harmonic oscillations**. The decision of this equation is a harmonic function

$$x(t) = A_0 \sin(\omega_0 t + \varphi), \quad \text{or} \quad x(t) = A_0 \cos(\omega_0 t + \varphi) \quad (1.6)$$

which sets the x coordinate of load in any moment of time t .

Let's consider descriptions of harmonic oscillations. Amplitude of A_o is most deviation of point from position of equilibrium.

$$\text{Cyclic frequency of oscillations } \omega_0 = \sqrt{\frac{k}{m}} \quad (1.7)$$

is an amount of oscillations for 2π seconds.

$$\text{Period of oscillations } T = \frac{2\pi}{\omega_0} \quad (1.8)$$

is time of one full-oscillate, or time for which the phase of oscillation changes on 2π .

$$\text{Frequency of oscillations } \nu = \frac{1}{T} \quad (1.9)$$

is an amount of oscillations for 1 second.

From (1.5) and (1.6) get the period of oscillation of the spring pendulum

$$T = 2\pi\sqrt{\frac{m}{k}} . \quad (1.10)$$

When load hangs on a spring, which does not carry out oscillations, it deforms a spring on the size of x_o . By Hook's law of $F = mg = kx_o$, it is possible to find rigidity of spring

$$k = \frac{mg}{x_o} . \quad (1.11)$$

Then a formula (1.8) for the period of oscillations assumes an air

$$T = 2\pi\sqrt{\frac{x_o}{g}} \quad (1.12), \quad \text{or} \quad T^2 = \frac{4\pi^2}{g} x_o . \quad (1.13)$$

Thus, experimentally measuring the period of oscillations of T and lengthening of spring of x_o , from its undeformed state to position of equilibrium at the different loadings, it is possible on the angle of slope of graph of $T^2 = f(x_o)$ (see a formula 1.13) to find the acceleration of the free falling. The first task is so executed.

The second task of work is executed on the basis of formula (1.10), that the linearness of dependence is checked up $T = f(\sqrt{m})$.

4. On results of every experience to expect rigidity of spring k on formula (1.9) and to find it mean value.

5. To build graphics: 1) $T^2 = f(x_0)$; 2) $T = f(\sqrt{m})$.

On lineal parts of graph (fig. 1.2) to choose for two points 1 ÷ 2 and 3 ÷ 4, to define their coordinates for to the axes, but not from a table, and after formulas (1.14) and (1.15) to expect g and k .

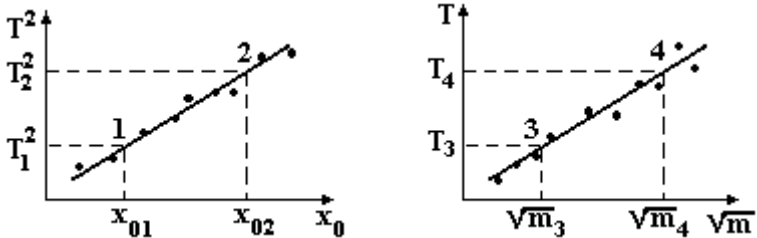

Figure 1.2

$$g = \frac{4\pi^2(x_{02} - x_{01})}{T_2^2 - T_1^2} \quad (1.14) \quad k = \frac{4\pi^2(\sqrt{m_4} - \sqrt{m_3})^2}{(T_4 - T_3)^2} \quad (1.15)$$

6. To draw conclusion, comparing the value of g to tabular, and k , got after a formula (1.15), with a mean value, found after a formula (1.11). In a conclusion also to mark or are line's graphic got in experiments and if so, then what does it testify to?

Control questions

1. What kind of oscillations is called harmonic? Write the dependence of deviation upon time for harmonic oscillations.
2. Give definitions for period, amplitude, frequency, cyclic frequency and phase.
3. Write the differential equation of harmonic oscillations.
4. Write the formula for period of a spring pendulum. What is a rigidity of a spring?

Author: V.K. Manko, assistant professor, candidate of physical and mathematical sciences.

Translator: S.P. Lushchin, assistant professor, candidate of physical and mathematical sciences.

Reviewer: S.V. Loskutov, professor, doctor of physical and mathematical sciences.

2 LABORATORY WORK № 42 MATHEMATICAL PENDULUM

Purpose of work: to measure the free fall acceleration.

INSTRUMENTATION AND APPLIANCES: mathematical pendulum; the stop-watch, straightedge.

2.1 Short theory

The point mass suspended by means of an inextensible weightless thread is called the *mathematical pendulum*. The restoring force is the projection of the force of gravity $\vec{P} = m\vec{g}$ on the direction of motion of the point mass. In this case

$$F = mg \cdot \sin \alpha,$$

where $\alpha = x/l$, the angle between positions of l in free state and deviation state.

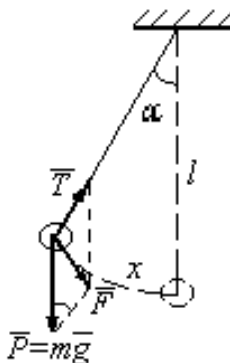

Figure 2.1

If the angles α are so small that $\sin \alpha \approx \alpha$, then

$$mg \cdot \sin \frac{x}{l} \approx mg \frac{x}{l}.$$

Since this force is always directed to the equilibrium position and that is why it has a sign opposite to that of x :

$$F = -mg \frac{x}{l}$$

In this case the oscillations are harmonic. The second Newton's law is

$$m \frac{d^2 x}{dt^2} = -mg \frac{x}{l}.$$

Finally we obtain the differential equation of harmonic oscillations:

$$\frac{d^2 x}{dt^2} + g \frac{x}{l} = 0.$$

If $g/l = \omega^2$, then

$$\frac{d^2 x}{dt^2} + \omega^2 x = 0.$$

Solution of this equation is

$$x = A \cos(\omega t + \varphi_0)$$

The cyclic frequency is

$$\omega = \sqrt{\frac{g}{l}},$$

and period is equal

$$T = 2\pi \sqrt{\frac{l}{g}},$$

i. e., the frequency and the period of oscillations do not depend on the mass of the oscillating body; they are determined only by the length of the thread and the free fall acceleration. The measurement of the period of a mathematical pendulum is used for determine g :

$$g = 4\pi^2 \frac{l}{T^2}.$$

2.2 Experimental part

1. Fix the end of the cord in the first position ($l = 50$ cm). Make the pendulum vibrate (the amplitude of vibration must not be more than the ball diameter). Determine time of 50 oscillations by the stop-watch three times and calculate the period T using the average value of the time.
2. Determine the free fall acceleration g .

3. Calculate an error.
4. Investigate relation between the period T and the length l . Put the end of the cord in the second position ($l = 150$ cm). Calculate period of oscillations T' in the same way and compare with T .
5. Increase the amplitude of oscillations twice. Test independence of the period on the amplitude of oscillations (small amplitude and big amplitude).
6. Make conclusions.

Control questions

1. What is a mathematical pendulum?
2. What kind of oscillations is called harmonic?
3. Write the differential equation of harmonic oscillations.
4. Write the dependence of deviation upon time for harmonic oscillations. Show this dependence in figure.
5. Give definitions for a period, an amplitude, a frequency, a cyclic frequency and a phase of vibration.

Translator: S.P. Lushchin, assistant professor, candidate of physical and mathematical sciences.

Reviewer: S.V. Loskutov, professor, doctor of physical and mathematical sciences.

3 LABORATORY WORK № 43.1 PHYSICAL PENDULUM

Purpose of work: check the dependence of physical pendulum free oscillations period from its moment of inertia; determine the value of the free fall acceleration.

Devices and equipment: physical pendulum, stopwatch, straightedge.

The experimental setting (fig.3.1) consists of the base 1, alignment of which is carried out by legs 2. The rack is fastened in the base 3, on which the bottom supporting arm 4 is fixed with photoelectric sensor 5. On the top supporting arm 6 is suspended the physical pendulum, which includes the rod 7, weight 8 and detent 9. On the rod 7 in 10 mm collar marks are made for the exact determination of the length and exact weight 8 fixation.

On the front gage panel there are: 10 – oscillation indicator, 14 – indicator of time, switches: -11 “Сеть”, 12 “Сбор”, 13 “Стон”.

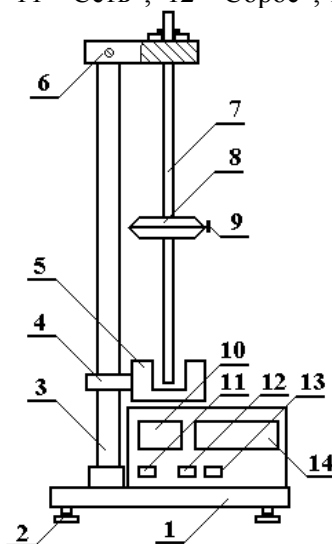

Figure 3.1

During the pendulum motion the flow of light from the lamp of the photoelectric sensor overlap and the electronic computation circuit of oscil-

lations number and stopwatch actuates. After pressing the switch “STOP” the stopwatch stanching after the end of full current oscillations.

3.1 Theoretical part

Physical pendulum – is the solid, which can rotate relatively to the arbitrary of the horizontal axis that doesn't pass through the center of mass. Moment of the gravity force mg , the arm of which is equal $L \cdot \sin \alpha$. Value of L is the distance from pivot O (suspension center) to point C – the center of the mass of the body. Under the action of this moment the body turns round the suspension center O .

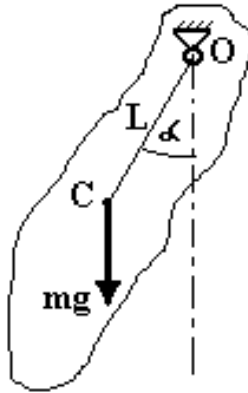

Figure 3.2

Write down the fundamental equation of the rotational motion dynamics

$$I \cdot \varepsilon = -mgL \cdot \sin \alpha, \quad (3.1)$$

where I is the moment of inertia of the body, $\varepsilon = \frac{d^2\alpha}{dt^2}$ is angular acceleration, minus accounts that the moment of force of mg reduces the angle α . Thus, we get the differential equation of physical pendulum free oscillations

$$\frac{d^2\alpha}{dt^2} + \frac{mgL}{I} \sin \alpha = 0. \quad (3.2)$$

If angle α is small (less than 5°) we can consider that $\sin \alpha = \alpha$. We get

$$\frac{d^2\alpha}{dt^2} + \frac{mgL}{I} \alpha = 0. \quad (3.3)$$

Comparing the received equation with the general equation of free harmonic oscillations

$$\frac{d^2\alpha}{dt^2} + \omega^2 \alpha = 0, \quad (3.4)$$

where $\omega = \sqrt{\frac{mgL}{I}} = \frac{2\pi}{T}$ - is cyclic frequency of oscillations, T - period.

Let's get the equation of the period of oscillations

$$T = 2\pi \sqrt{\frac{I}{mgL}}. \quad (3.5)$$

Equation solution (3.4) is the harmonic function which is the equation of free harmonic oscillations

$$\alpha = \alpha_0 \sin(\omega t + \varphi). \quad (3.6)$$

For performing the first task point we need to change the moment of inertia of the pendulum. It is carried out by moving the weight 8 along the rod 7. But in this way the mass center position changes, it is the distance L .

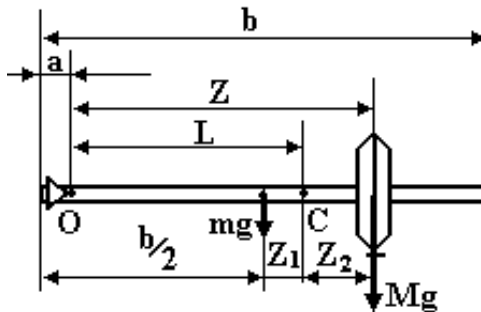

Figure 3.3

The moment of inertia of the pendulum relatively to the point \mathbf{O} is equal to the amount of moment of inertia of the load and rod.

$$I_{load} = MZ^2$$

Taking into account Steiner theorem, we obtain

$$I_{rod} = \frac{1}{12}mb^2 + m\left(\frac{b}{2} - a\right)^2.$$

Thus, the moment of inertia of the pendulum as function of distance \mathbf{Z} from point of suspension to weight center

$$I = MZ^2 + \frac{1}{12}mb^2 + m\left(\frac{b}{2} - a\right)^2. \quad (3.7)$$

Let's find the position of point \mathbf{C} the mass center of pendulum which is the distance \mathbf{L} as function \mathbf{Z} . By the law of moments relatively to the point \mathbf{C} we have:

$$mgZ_1 = MgZ_2. \quad (3.8)$$

From figure 3 we can see that

$$L = Z - Z_2, \quad Z_1 + \frac{b}{2} = L + a. \quad (3.9)$$

From equations (3.8) – (3.9) we get

$$L = \frac{Z + \frac{m}{M}\left(\frac{b}{2} - a\right)}{1 + \frac{m}{M}}. \quad (3.10)$$

Substitution of (3.7) and (3.10) into (3.5) after squaring (3.5) gives us

$$Y = g \cdot X - Y_0, \quad (3.11)$$

where

$$Y = Z^2, \quad Y_0 = \frac{1}{12}b^2 \frac{m}{M} + \frac{m}{M}\left(\frac{b}{2} - a\right)^2,$$

and

$$X = \frac{T^2 \left[Z + \frac{m}{M}\left(\frac{b}{2} - a\right) \right]}{4\pi^2}. \quad (3.12)$$

Thus, dependence $\mathbf{Y} = \mathbf{f}(\mathbf{X})$ according to the theory, must be linear. Experimentally researched is the dependence of oscillations period \mathbf{T} of

physical pendulum and distance Z from weight to suspension center. We plot the graph (3.12)

$$Y=f(X).$$

If you get a rectilinear graph, it confirms validity of theoretical formulas (3.5) and (3.7), and on its slope we can find the free fall acceleration g . Its coincidence with tabulated value 9.8 m/s^2 confirms truth of the theoretical ratio.

3.2 Work procedure

1. Connect a device to the mains 220 V and push the button „Сеть”.
2. Remove the pendulum from the support arm 6, release the detent 9 and station the weight 8 center on the distance 10 cm from the suspension point. Measure the distance with the number of known collar marks on the rod from supportive prisms (suspension center) plus 1 cm to the weight which includes the thickness of the load (2 sm). Seek a clear fixing of a load in marks.
3. Hang up the pendulum on the supportive arm 6. Watch after its mounting reliability.
4. Regulate the supportive arm 4 position so that the bottom rod end of physical pendulum 7 won't catch on photoelectric sensor 5, but block its ray.
5. Activate physical pendulum in oscillations, having rejected it on a corner less than 5° .
6. After the pendulum make $1 \div 2$ oscillations, push the button “Сброс”. Counting of time and oscillations number will start which will be visible on corresponding indicators.
7. When oscillations indicator shows up number 9, press the button “Стой”. The last 10-th oscillation will finish and the stopwatch will stop.
8. Define the period of oscillations, dividing time for oscillations number that is 9. Distance Z and period T write down to the table.
9. Repeat points 2÷8, removing the weight down in 2 cm to the possibly lowest weight position.
10. Under formula (3.12) calculate X and write it down to the table. Pendulum parameters are: mass ratio $\frac{m}{M} = 0,3$; Length of the bottom rod end to

suspension point $a = 5$ cm; total rod length $b = 59$ cm. Calculation it is more convenient to do on the computer.

11. Plot the dependence $Y = f(X)$ and choose two points 1 and 2 on its rectilinear part and define its coordinate by axes, not from the table, on the graph inclination find the free fall acceleration by the formula

$$g = \frac{Y_2 - Y_1}{X_2 - X_1}, \text{ cm/s}^2. \quad (3.13)$$

Compare the received value with reference 980 cm/s^2 . Write the conclusion.

Table 3.1

Z, cm	$Y=Z^2$, cm^2	T, s	X, $\text{cm}\cdot\text{s}^2$

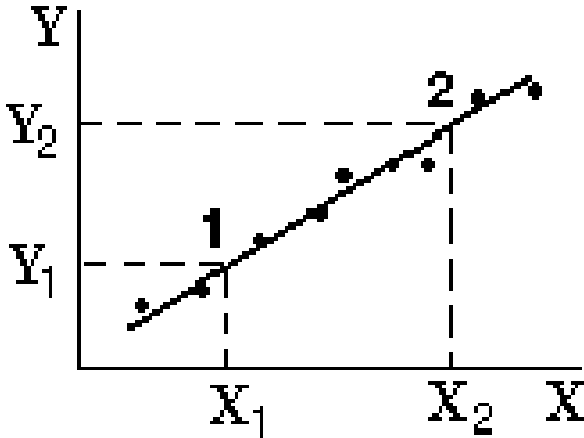

Figure 3.4

Control questions

1. What is the physical pendulum?
2. Deduce and write down the differential equation of physical pendulum's free harmonic oscillations.
3. Write down the oscillations equation which is the solution of physical pendulum differential equation. Plot the graph of this equation.
4. What is the name of values which are a part of physical pendulum oscillations equation? What units they have?
5. Write down formulas for period and physical pendulum's cyclic oscillation frequency.

Author: V.K. Manko, assistant professor, candidate of physical and mathematical sciences.

Translator: S.P. Lushchin, assistant professor, candidate of physical and mathematical sciences.

Reviewer: S.V. Loskutov, professor, doctor of physical and mathematical sciences.

4 LABORATORY WORK № 43.2 OSCILLATION OF PEG

Purpose of work is to probe dependence of period of oscillations of peg on distance between the axis of rotation and center of peg.

Devices and accessories: peg, straightedge, stop-watch.

Task of work: 1) to build the theoretical and experimental graph of dependence of period of oscillations T of peg from dimensionless length a/l : $T = f(a/l)$;

2) to find minimum functions $T = f(a/l)$ by an experimental and theoretical way.

4.1 Theoretical part

Will consider oscillation of peg, position of axis of which, it is possible to change along a peg. Such peg shows by itself a physical pendulum. The period of oscillation of the physical pendulum is determined by formula

$$T = 2\pi \sqrt{\frac{I}{mga}}, \quad (4.1)$$

Where I is a moment of inertia of peg, m is mass, a is distance from the axis of rotation to the center of the masses, g is the free fall acceleration. The moment of inertia I in this case is determined on the theorem of Steiner:

$$I = I_0 + ma^2, \quad (4.2)$$

where I_0 is a moment of inertia of peg in relation to an axis which go athwart to the peg through his center:

$$I_0 = \frac{ml^2}{12} \quad (4.3)$$

After a substitution (8.2) and (8.3) in a formula (8.1) get:

$$T = 2\pi \sqrt{\frac{l^2}{12ga} + \frac{a}{g}} \quad (4.4)$$

In the formula (4.4) the size a can change in the interval: $[0, l/2]$.

1. At $a \rightarrow 0$, period $T \rightarrow \infty$, that at fixing of peg in a center of peg it will not oscillate in general, in this case the total moment of forces which operate on a peg in any its position will equal a zero.

2. At $a = \frac{1}{2}$ for T get:

$$T = 2\pi \sqrt{\frac{2l}{3g}} \quad (4.5).$$

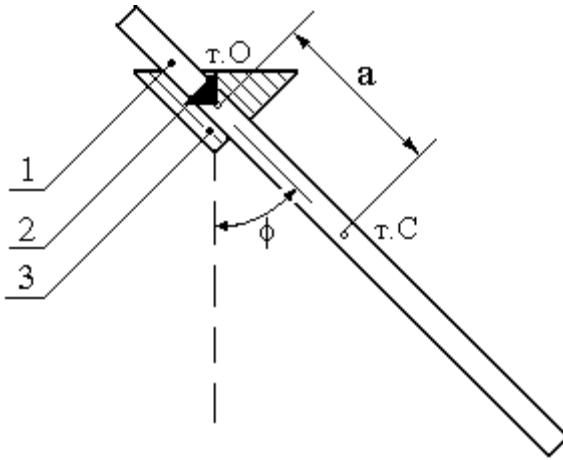

Figure 4.1

3. Research of formula (4.4) shows on the extremum, that a function has minimum, a coordinate of which is from a condition $\frac{dT}{da} = 0$. After differentiation (4.4) find, that a function has minimum at

$$a = \frac{1}{2\sqrt{3}}, \quad (4.6)$$

or approximately at $a \approx 0.29 \cdot l$.

For experimental research of dependence of period of oscillations of peg from position of axis of rotation a device, represented in fig. 4.1, is used. If peg 1 to set a supporting prism 2 on a bracket 3, to show out of position of equilibrium on some corner ϕ and to release, then he will carry out oscillation in relation to position of equilibrium.

4.2 Practical part

1. Measure length of peg - l .
2. Set a supporting prism 2 on the first value from a table.
3. Set a peg on a bracket 3.
4. Show a pendulum out of position of equilibrium on a corner $\phi \approx 10 \div 15^\circ$ and to release; to measure time 10 full oscillations. Write down the period of T to the table 4.1.
5. Repeat measurings with other the values a which are indicated in a table 4.1.

Table 4.1

n	a/l	a , cm	T, s		l, cm
			experiment	theory	
1	0,01				
2	0,02				
3	0,03				
4	0,04				
5	0,05				
6	0,1				
7	0,2				
8	0,3				
9	0,4				
10	0,45				

6. After a formula (4.4) to expect the theoretical values of period of T . To compare the experimental and theoretical values of period.
7. On one field (it is desirable on a plotting paper) to build theoretical and experimental graph $T = f\left(\frac{a}{l}\right)$ according to sample, which is presented in fig. 4.2.
8. Find the first derivative of function (4.4) on a parameter . From a condition $\frac{dT}{da} = 0$ to find the theoretical value of co-ordinate of a

minimum of function; to compare a theoretical value to experimental, found for graphic $T = f\left(\frac{a}{l}\right)$.

Draw conclusion.

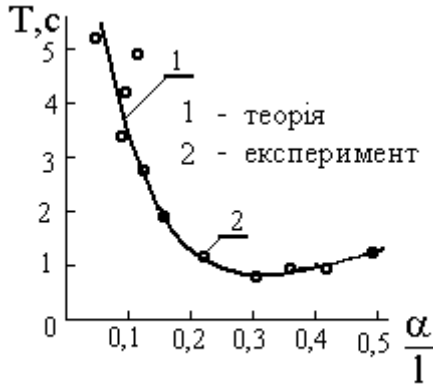

Figure 4.2

Additionally. To build theoretical and experimental graph by a computer.

For more detailed research of a minimum of function (4.4) do the additional measurements of period of oscillations in an interval with a less step (for example - $0.02l$). Expect the theoretical values of period at those values. Compare a theory to the experiment, building graphic arts. Draw conclusion, in relation to justice of formulas (4.1) – (4.4).

Control questions

1. What harmonic oscillations? Write down differential equalization of harmonic oscillations and his decision.
2. What is physical pendulum? Write down the formula of the period of oscillation of the physical pendulum.
3. Formulate the theorem of Steiner.
4. Draw the graph of the dependence of period of oscillations of peg from distance between the axis of rotation and pegcenter.

Author: M.I. Pravda, the reader, candidate of physical and mathematical sciences.

Reviewer: S.V. Loskutov, professor, doctor of physical and mathematical sciences.

5 LABORATORY WORK № 43.3 DETERMINATION OF THE RESULTED LENGTH OF PHYSICAL PENDULUM

Purpose of work: study of laws of oscillation physical and mathematical pendulums.

Task: experimentally and theoretically to find resulted length of physical pendulum.

Devices and equipment: physical pendulum, mathematical pendulum, straightedge, stop-watch. The experimental setting (fig.5.1) consists of physical 1 and mathematical 2 pendulums.

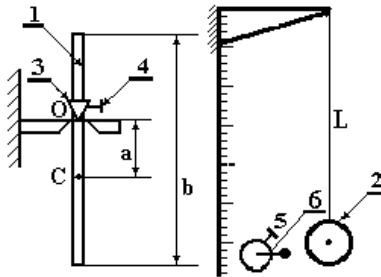

Figure 5.1

Length of mathematical pendulum can be fluently changed, reeling it in 5 and to fix spirally 6.

5.1 Theoretical part

A physical pendulum is a body which can be revolved relatively of arbitrary horizontal axis, that not go through the center of mass. Under the action of moment of force mg , the arm of which is $L \cdot \sin \alpha$, a body is revolved round the point of hang up O (fig.5.2). L is distance from a point O rotation (points of hang up) to the point of C - center of mass of body. Write down the fundamental equation of the rotational motion dynamics

$$I \cdot \varepsilon = -mgL \cdot \sin \alpha, \quad (5.1)$$

I is a moment of inertia of body, $\varepsilon = \frac{d^2\alpha}{dt^2}$ is angular acceleration. A sign does minus take into account, that the moment of force of mg is diminished by a corner α .

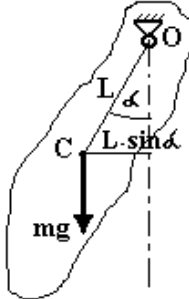

Figure 5.2

Thus, get differential equation of undamped oscillation of the physical pendulum

$$\frac{d^2\alpha}{dt^2} + \frac{mgL}{I} \sin \alpha = 0. \quad (5.2)$$

At small corners α (less 5°) is it possible, that $\sin \alpha = \alpha$. Get

$$\frac{d^2\alpha}{dt^2} + \frac{mgL}{I} \alpha = 0 \quad (5.3)$$

Comparing this equation to general equation of undamped harmonic oscillations

$$\frac{d^2\alpha}{dt^2} + \omega_0^2 \alpha = 0, \quad (5.4)$$

get cyclic frequency $\omega_0 = \sqrt{\frac{mgL}{I}} = \frac{2\pi}{T}$ and period of oscillation of the physical pendulum

$$T = 2\pi\sqrt{I/mgL} \quad (5.5)$$

Thus, the period of oscillation of the physical pendulum depends on position of point of hang up O and forms of body, that to its moment of inertia in relation to this point.

For a mathematical pendulum, which is a material point, suspended on a weightless unstretching thread long L , moment of inertia is $I = mL^2$, $a = L$. Consequently the period of oscillation of the mathematical pendulum depends only on length of thread

$$T_M = 2\pi\sqrt{L/g} . \quad (5.6)$$

The resulted length of L_{res} of physical pendulum is such length of mathematical pendulum the period oscillation of which equals the period of oscillation of the physical pendulum. From (5.5) and (5.6) we have

$$L_{np} = \frac{I}{ma} . \quad (5.7)$$

A moment of inertia of peg (fig.10.1) is taking into account a theorem Steiner

$$I = \frac{1}{12}mb^2 + ma^2 . \quad (5.8)$$

Thus, from (5.7) and (5.8) get the theoretical value of the resulted length

$$L_{reop} = \frac{b^2}{12a} + a . \quad (5.9)$$

Find the theoretical value of period of oscillation of the physical pendulum from (5.5) and (5.8)

$$T_{reop} = 2\pi\sqrt{\frac{b^2}{12ag} + \frac{a}{g}} . \quad (5.10)$$

5.2 Practical part

1. Take off a physical pendulum from a bracket.
2. By a line to measure general length of b peg.
3. Set a supporting prism 3 in the distance and $a = 20 + N$ of see from his middle and to fix its spirally 4. N is a number of educational brigade.
4. Hang up a physical pendulum.
5. Decline mathematical and physical pendulums on a corner approximately 5° and to release.

6. By sight to watch after synchronousness of oscillations of both pendulums. In case, if the period of mathematical pendulum more than (less) physical, to decrease (to increase) length of thread of mathematical pendulum.
7. To repeat points 5, 6 to coinciding of periods of oscillations of pendulums, that synchronous oscillation during not less than 20 oscillations.
8. To measure time t of 20 oscillations of pendulums and to find a period $T_{\text{excn}} = \frac{t}{20}$.
9. By a line to measure length of mathematical pendulum from the point of hang up to the center of peg. It will be experimental value of the resulted length of physical pendulum of L_{exp} .
10. Expect the theoretical values of the resulted length after a formula (5.8) and period after a formula (5.10).
11. Compare the experimental and theoretical values of resulted length and to the period, writing down them in a table 5.1.

Table 5.1

$L_{\text{theory}}, \text{sm}$	$L_{\text{exp}}, \text{sm}$	$T_{\text{theory}}, \text{s}$	$T_{\text{exp}}, \text{sm}$

12. Expect the error of L_{theory} .

Control questions

1. What is physical pendulum?
2. What is mathematical pendulum?
3. Get differential equation of free harmonic oscillation of the physical pendulum.
4. Get the period of oscillation of the physical pendulum.
5. Get the period of oscillation of the mathematical pendulum.
6. Give determination of the resulted length of physical pendulum.
7. Get expression for the resulted length of physical pendulum.

Author: V.K. Manko, assistant professor, candidate of physical and mathematical sciences.

Translator: S.P. Lushchin, assistant professor, candidate of physical and mathematical sciences.

Reviewer: S.V. Loskutov, professor, doctor of physical and mathematical sciences.

6 LABORATORY WORK № 43.4 DETERMINATION OF THE FREE FALL ACCELERATION WITH HELP OF REVERSIBLE PENDULUM

Purpose of work: to study the method of determination of acceleration of the free falling by reversible pendulum.

Task: to measure the acceleration of the free falling - g .

Devices and equipment: reversible pendulum, electronic stopwatch.

6.1 Experimental installation description

Experimental installation is represented in figure 6.1. On a vertical column 1, which is established on the base 2 with electronic stopwatch 3 placed on it, are fixed two arms: the bottom mobile 4 with the photo-electric gauge 5 and the top motionless 6. On the top motionless arm 6 is suspended reversible pendulum, looking like a steel peg on which are fixed

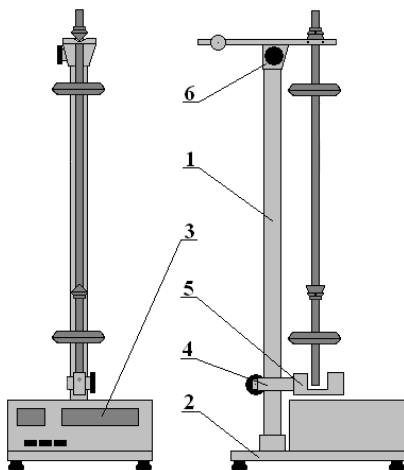

Figure 6.1

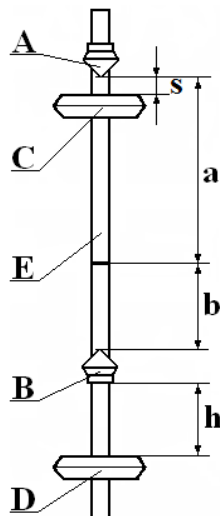

Figure 6.2

support knife-edge A and B and mobile weights C and D (figure 6.2).

6.2 Theoretical part

In every physical pendulum it is possible to find two such points on its axis, which period of oscillations will remain constant at consecutive pinning of the pendulum in this or that point. In our case of reversible pendulum these two points are location of prisms A and B (figure 6.2). It is possible to achieve equal oscillations periods by prisms A and B pinning of the reversible pendulum moving weights C and D on its axis:

$$T_A = T_B = T = 2\pi \sqrt{\frac{I_A}{mga}} = 2\pi \sqrt{\frac{I_B}{mgb}} \quad (6.1)$$

where I_A and I_B – second moments of a pendulum concerning axis which pass through points A and B ; a and b – spacing from the center of gravity to applicable oscillations axis. In terms of Steiner theorem:

$$I_A = I_0 + ma^2, \quad I_B = I_0 + mb^2 \quad (6.2)$$

where I_0 – second moment of a pendulum concerning axis which passes through its center of gravity and which is parallel to the oscillations axis.

Substituting (6.2) in (6.1), we will get the computation formula for the free fall acceleration g :

$$g = \frac{4\pi^2(a+b)}{T^2} \quad (6.3)$$

Size $L=a+b$, which is equaled to a spacing between prisms, is named an ***equivalent length of a physical pendulum***. Thus, for sizing of the free fall acceleration with help of reversible pendulum is necessary to measure two sizes: equivalent length L and swinging period $T=T_A=T_B$ of physical pendulum.

6.3 Practical part

1. Connect a device power cord to the mains and push the button "NET".
2. Check up indicators and bulbs work of photoelectric sensor: electronic stopwatch indicators and oscillations number (periods) counter have to indicate "0" in all discharges and photoelectric sensor bulb glow.
3. Fix weight C on the distance $s=5+n$ sm (where n – number of an educational brigade) from prism A , and weight D – on distance $h=1$ from prism B (figure 6.2).
4. Find the spacing L between prisms, using a scale which is coated on a rod.
5. Fix the pendulum on the top supporting wedge of the plant on prism A .
6. Displace the bottom supporting wedge of the plant so that the pendulum rod crossed the photoelectric sensor optic axis.
7. Deviated a pendulum from equilibrium position on a corner $5-10^\circ$, give an opportunity to make free oscillations.
8. Push the button "DISCHARGE".
9. Measure the time of full pendulum oscillations for what after full oscillations calculation push the button "STOP" on the stopwatch.
10. Calculate the pendulum oscillations period T under the formula:

$$T = \frac{t}{N}, \quad (6.4)$$

where t – total time N oscillations.

Count up the oscillations period T_A for different positions h of weight D on the pendulum rod according to points 7-10. Change weight D position on the pendulum rod through each basic scale division that is through 1 sm. But weight C position remains constant. Enter computational results in the table 6.1.

11. Hang up the pendulum on the prism B .
12. Lift the bottom supporting wedge with photoelectric sensor according to p. 6.
13. Determine pendulum oscillations period T_B for weight D different

positions *on the rod E* in the same bounds and with that number of measurements. Put down computational results in the table 6.1.

14. According to the table 1 graph oscillations periods T_A and T_B plot from the weight D position h on the pendulum rod on mm paper: $T_A=f(h)$ and $T_B=f(h)$. Intersection of curves will determine movable weight D position on the pendulum rod, at which periods values will be equal $T_A=T_B=T$.
15. Find pendulum oscillations periods for this weight D position according to points 7÷10 concerning to prisms A and B . Conduct oscillations periods measurement concerning to each prism 3 times. Enter computational results in the table 6.2:

16. Calculate the pendulum oscillations period \bar{T} under the formula:

$$\bar{T} = \frac{\bar{T}_A + \bar{T}_B}{2} \quad (6.5)$$

17. Calculate the free fall acceleration \bar{g} under the formula (12.3). Submit the result in a following form:

$$g_{\text{exp}} = \bar{g} \pm \Delta g ,$$

where Δg – absolute error g , which can be found from the formula:

$$\varepsilon = \frac{\Delta g}{\bar{g}} = \sqrt{\left(\frac{2\Delta\pi}{\pi}\right)^2 + \left(\frac{\Delta L}{L}\right)^2 + \left(\frac{2\Delta T}{\bar{T}}\right)^2} \cdot 100\% . \quad (6.6)$$

Value of $\Delta\pi$ is counted as a mistake of tabular size; ΔL – as direct unit measurement error.

Absolute error \bar{T} can be found under the formula:

$$\Delta T = \frac{1}{2} \sqrt{\Delta T_A^2 + \Delta T_B^2} , \quad (6.7)$$

where ΔT_A , ΔT_B are founded as direct repeated measurement error .

18. Compare received experimental value $g_{\text{excn}} = \bar{g} \pm \Delta g$ with reference $g_{\text{ooe}} = 9,81 \text{ m/c}^2$.
19. Write a conclusion.

Table 6.1

№	h, sm	T_A, c	T_B, c
1	1		
2	2		
3	3		
4	4		
5	5		
6	6		
....
n	n		

Table 6.2

№	T_{Ai}, c	$\Delta T_{Ai}, \text{c}$	$[\Delta T_{Ai}]^2, \text{c}^2$	T_{Bi}, c	$\Delta T_{Bi}, \text{c}$	$[\Delta T_{Bi}]^2, \text{c}^2$
1						
2						
3						
	$\bar{T}_A =$, c	—	$\Sigma[\Delta T_{Ai}]^2 =$, c ²	$\bar{T}_B =$, c	—	$\Sigma[\Delta T_{Bi}]^2 =$, c ²

Control questions

1. What is the free fall acceleration? What is the direction of free fall acceleration and on what it depends?
2. Define the physical pendulum.
3. Deduce a formula for the physical pendulum oscillations period.
4. Define a physical pendulum reduced value?
5. State the Steiner theorem.

Author: S.V. Seidametov, assistant.

Reviewer: S.V. Loskutov, professor, doctor of physical and mathematical sciences.

7 LABORATORY WORK № 43.5 TORSION PENDULUM

Purpose of work is to study of laws of oscillations of the torsion pendulum.

Task: check up dependence of period of free oscillations torsion pendulum from its moment of inertia; check up a formula for the moment of inertia of ball (peg).

Devices and equipment: torsion pendulum, set of cylinders or pegs, balls.

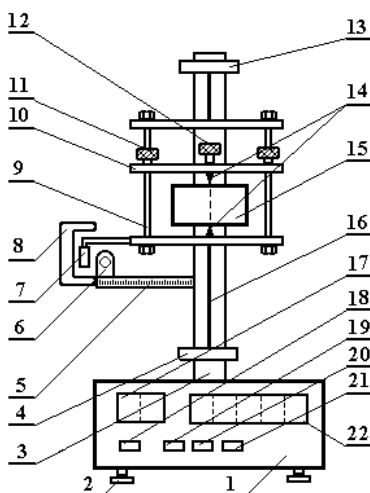

Figure 7.1

The experimental setting (fig.7.1) consists of basis 1. In basis a peg is fastened 3, on what fix lower bracket 4 and overhead 13. On these brackets on a steel wire 16 the suspended scope 9, which has a moving slat 10 with two fixative nuts 11. In a scope on two centring dowels 14 the probed body is fastened 15 (cylinder, peg, cube, ball) and it is compressed spirally 12. On a scope small flag is fastened 7, which, crossing the light ray of photoelectric sensor 8, includes the electronic system of count of amount oscillations (indicator 17) and stop-watch (indicator 22). After help of this small flag a scope of fix is in initial position of electromagnet 6 at certain

corner of turn which is measured on a scale 5. On the front panel of device are: switches 18 – “Сеть”, 19 – “Сброс”, 20 – “Пуск”, 21 – “FEET”.

7.1 Theoretical part

A turning pendulum is a body, which can be revolved in relation to an arbitrary axis under the action of resilient force, which arises up during deformation of twisting of wire, which the fastened body is on. Write down the fundamental equation of the rotational motion dynamics

$$M = I \cdot \varepsilon, \quad (7.1)$$

where I is a moment of inertia of body, $\varepsilon = \frac{d^2\alpha}{dt^2}$ is an angular acceleration.

During deformation of twisting of wire the moment of force is proportional the corner of rollup, that

$$M = -k \cdot \alpha \quad (7.2).$$

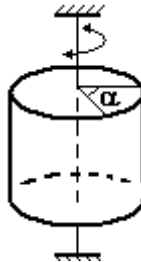

Figure 7.2

A sign does minus take into account, that the moment of force is diminished by the corner of turn α . Get differential equation of oscillations of the turning pendulum

$$\frac{d^2\alpha}{dt^2} + \frac{k}{I}\alpha = 0. \quad (7.3)$$

Comparing this equation to general equation of undamped harmonic oscillations

$$\frac{d^2\alpha}{dt^2} + \omega_0^2\alpha = 0, \quad (7.4)$$

get cyclic frequency $\omega_0 = \sqrt{\frac{k}{I}} = \frac{2\pi}{T}$ and period of oscillation of the turning pendulum

$$T = 2\pi\sqrt{I/k}. \quad (7.5)$$

For implementation of the first point of task it is necessary to change the moment of inertia of pendulum. It is carried out replacement of bodies which are fastened in a scope 9. For this purpose the complete set of loads is used with different geometrical sizes, but with identical mass. A moment of inertia of cylinder is in relation to its axis

$$I_u = \frac{1}{2}m \cdot R^2 \quad (7.8)$$

Moment of inertia of peg in relation to an axis, what perpendicular to it and passes through his middle

$$I_c = \frac{1}{12}m \cdot L^2 \quad (7.8)$$

A moment of inertia of ball is in relation to a diameter

$$I_k = \frac{2}{5}m \cdot R^2 \quad (7.9)$$

The substitution of this expressions in a formula (7.5), taking into account the moment of inertia of scope of I_p and additivity of moment of inertia, enables to calculate the periods of oscillations:

cylinder
$$T_u = 2\pi\sqrt{\frac{I_p + \frac{1}{2}mR^2}{k}}, \quad (7.10)$$

peg
$$T_c = 2\pi\sqrt{\frac{I_p + \frac{1}{12}mL^2}{k}}, \quad (7.11)$$

balls
$$T_k = 2\pi\sqrt{\frac{I_p + \frac{2}{5}mR^2}{k}}. \quad (7.12)$$

Bringing expressions (7.10), (7.11) and (7.12) to the square, get:

$$T_u^2 = \frac{4\pi^2}{k} I_p + \frac{4\pi^2}{k} \cdot \frac{1}{2} mR^2 \sim R^2 \quad (7.13)$$

$$T_c^2 = \frac{4\pi^2}{k} I_p + \frac{4\pi^2}{k} \cdot \frac{1}{12} mL^2 \sim L^2 \quad (7.14)$$

$$T_k^2 = \frac{4\pi^2}{k} I_p + \frac{4\pi^2}{k} \cdot \frac{2}{5} mR^2 \sim R^2 \quad (7.15)$$

From formulas (7.13) - (7.15) evidently, that the squares of periods of oscillations are proportional the squares of the proper characteristic geometrical sizes of bodies (radius, length).

For the period of oscillations of scope without loads have

$$T_p^2 = \frac{4\pi^2}{k} I_p. \quad (7.16)$$

Replacing in expressions (7.13) are (7.15) the first elements by expression (7.16), get

$$T_u^2 = T_p^2 + \frac{4\pi^2}{k} \cdot \frac{1}{2} mR^2, \quad (7.17)$$

$$T_c^2 = T_p^2 + \frac{4\pi^2}{k} \cdot \frac{1}{12} mL^2 \sim L^2, \quad (7.18)$$

$$T_k^2 = T_p^2 + \frac{4\pi^2}{k} \cdot \frac{2}{5} mR^2 \sim R^2. \quad (7.19)$$

Thus, dependences of squares of periods on the squares of the proper characteristic sizes after a theory must be linear. Thus segment which chops off a chart on wasp of ordinates (squares of periods) equals the square of period of oscillations of free scope, and does the tangent of angle of slope of graph depend on the coefficient of proportion k between a rotary-type moment and corner α (wonders formula (7.2)). Dependence is experimentally probed between the period of oscillations of T of turning pendulum and radius of cylinders (long pegs). A chart is built in the co-ordinates of $T^2 = f(R^2)$ for cylinders, whether $T^2 = f(L^2)$ for pegs. If a graphic will be lineal,

then it high-quality confirms justice of theoretical formulas (7.17) and (7.18), and coinciding of values, which chop off this graphic on wasp of ordinates, with the square of period of scope in number confirm justice of these formulas. Except for it, on the tangent of angle of slope of the indicated graph it is possible to find a coefficient k , and more precisely relation of m/k^2 , and after a formula (7.19) to calculate the period of oscillations of T_k . If it a calculation value will be near to directly measured, it will confirm justice of theoretical formulas, and in particular, formulas (7.9).

7.2 Practical part

1. To plug a device in a network 220 V and to press the switch of „CETБ ”.
2. To press the switch of “СБРОС”. Carefully to turn a scope to its fixing due to reaching of small flag by a 7 electromagnet 6.
3. To press a switch „ПЙСК”. An electromagnet will release a scope, and it will begin to carry out turning oscillations. An electronic block will deduct the amount of full oscillations and time of oscillations.
4. When a number 9 will appear on the indicator of amount of oscillations, to press a switch “СТОП”. Upon termination of 10th oscillation stopwatch of stop.
5. To define the period of oscillations, dividing time into the amount of oscillations, that on 10.
6. To push back a switch “ПЙСК”. To execute measuring of period of oscillations of T_r in obedience to points 2 ÷ 5 three times. To add results to the table 7.1.

Table 7.1

№	T, s	ΔT , s	$(\Delta T)^2$, s ²
1			
2			
3			
	$\overline{T}_p =$		$\sum(\Delta T_{pi})^2 =$

Measure a Vernier calipers the diameters of cylinder (length of peg) and ball. Carefully, not to cut a wire short, fasten a load in a scope. For this

purpose to release nuts 11, to move a slat 10 up, how downward, that centrings dowels 14.

7. Got in openings on a load. To twirl nuts and clutch a load spirally 12. To fasten a cylinder along his axis, peg - athwart to the plane of scope.
8. Like points 2 ÷ 5 to measure the period of oscillations on once for all loads, including for a ball. To add the results of measurings to the table 7.2.

Table 7.2.

№	$R (L), \text{mm}$	T, s	T^2, s^2	$R^2 (L^2), \text{mm}^2$
1				
2				
3				
4				
5				
Ball				

9. To build the chart of dependence of $T^2 = f(R^2)$, or $T^2 = f(L^2)$. To continue a chart to crossing with the axis of ordinates and on a segment which is chopped off on it, to define the square of period of oscillations of free scope T_p^2 .
10. On lineal part of graphic (fig.7.2) a little rather one from the second to choose two points 1 and 2. To define their co-ordinates for to the axes, but not from a table. To find the tangent of corner φ to inclination of graphic by formula

$$\operatorname{tg}\varphi = \frac{T_2^2 - T_1^2}{R_2^2 - R_1^2}, \quad (7.20)$$

or

$$\operatorname{tg}\varphi = \frac{T_2^2 - T_1^2}{L_2^2 - L_1^2}. \quad (7.21)$$

11. After formulas (7.17), (7.20) for cylinders, or (7.18), (7.21) for pegs to calculate a numerical value

$$\frac{4\pi^2 m}{k} \quad (7.22)$$

12. Putting the got value, and also mean value T_p^2 , from a table 1 in a formula (7.19), calculate the square of period of oscillations of ball T_k^2 and compare it to directly measured (see a table 7.2).
13. To define the value of ordinate which is chopped off by the graphic $T^2 = f(R^2)$. To compare this value to the square of period of oscillations of scope.
14. Draw conclusion that to implementation of laws of oscillations of the turning pendulum, and also about justice of formulas for the moments of inertia of cylinder, peg, ball.

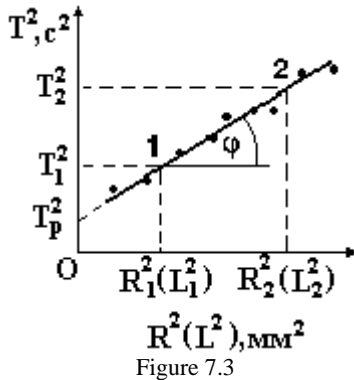

Control questions

1. What is turning pendulum?
2. Make and write down differential equation of free harmonic oscillations of the turning pendulum.
3. Write down equation of oscillations, which is the decision of differential equation of harmonic oscillations. Draw the graph of this equation.
4. Write down formulas for a period and cyclic frequency of oscillations of the turning pendulum.

Author: V.K. Manko, assistant professor, candidate of physical and mathematical sciences.

Translator: S.P. Lushchin, assistant professor, candidate of physical and mathematical sciences.

Reviewer: S.V. Loskutov, professor, doctor of physical and mathematical sciences.

8 LABORATORY WORK № 43.6 OSCILLATION OF HOOP

Purpose of work: study of laws of swing of the physical pendulum. To check up the formula of period of oscillations of the physical pendulum.

Task: 1) experimentally to measure the period of oscillations of hoop in relation to the point of hang up O , which is on it (fig 8.1);
2) calculate the theoretical value of period.

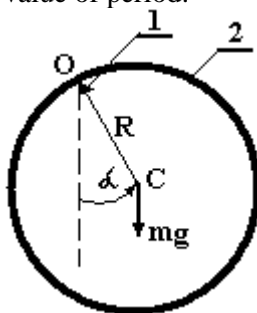

Figure 8.1

Devices and equipment: hoop (physical pendulum), stop-watch, line.

Experimental setting: on a bracket a 1 suspended hoop 2.

8.1 Theoretical part

A physical pendulum is a body which can be revolved relatively of arbitrary horizontal axis, that not go through the center of mass. Under the action of moment of force mg , the arm of which is evened $L \cdot \sin \alpha$, a body is revolved round the point of hang up O (fig 8.2). L is distance from a point O rotation (points of hang up) to the point of C - center of mass of body. Write down the fundamental equation of the rotational motion dynamics

$$I \cdot \varepsilon = -mgL \cdot \sin \alpha, \quad (8.1)$$

I is a moment of inertia of body, $\varepsilon = \frac{d^2 \alpha}{dt^2}$ is an angular acceleration. A sign does minus take into account, that the moment of force of mg is diminished by a corner α . Thus, get differential equation of undamped oscilla-

tions physical pendulum

$$\frac{d^2\alpha}{dt^2} + \frac{mgL}{I} \sin \alpha = 0. \quad (8.2)$$

At small corners α (less 5°) is it possible, that $\sin \alpha = \alpha$. Get

$$\frac{d^2\alpha}{dt^2} + \frac{mgL}{I} \alpha = 0. \quad (8.3)$$

Comparing this equation to general equation of undamped harmonic oscillations

$$\frac{d^2\alpha}{dt^2} + \omega_0^2 \alpha = 0 \quad (8.4)$$

get cyclic frequency $\omega_0 = \sqrt{\frac{mgL}{I}} = \frac{2\pi}{T}$ and period of oscillations of the physical pendulum

$$T = 2\pi\sqrt{I/mgL}. \quad (8.5)$$

Thus, the period of oscillations of the physical pendulum depends on position of point of hang up O and forms of body, that to his moment of inertia in relation to this point. In our case for the hoop of $L = R$, and the moment of inertia taking into account the theorem of Steiner is evened

$$I = I_0 + mR^2 = mR^2 + mR^2 = 2mR^2. \quad (8.6)$$

Thus period of oscillation of hoop

$$T = 2\pi\sqrt{2R/g} = 2\pi\sqrt{D/g}. \quad (8.7)$$

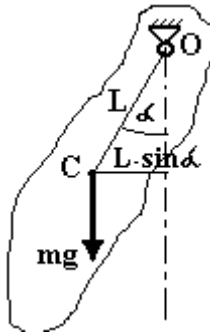

Figure 8.2

8.2 Practical part

1. To drive a hoop to oscillation, declining him on a corner not greater, than 5° .
2. In moment, when a hoop is in one of extreme positions, to include a stop-watch and measure time of t of twenty ($N=20$) oscillations.
3. To repeat an experiment in obedience to 1-2 yet 4 times (in all 5). To add results to the table 8.1.

Table 8.1

	t_i, s	$\Delta t_i = t_i - \bar{t}, s$	$\Delta t_i^2, c^2$	D, sm	T, s	T, c
1						
2						
3						
4						
5						
	$\bar{t} =$		$\sum (\Delta t_i^2) =$			

4. Calculate the mean value of time and error of his measuring as direct 5-th multiple measuring.
5. After a formula $T_{\text{эксп}} = \frac{\bar{t}}{N}$ to find the experimental value of period, and his error.
6. To take off a hoop from a bracket and measure the line of him the middle diameter of D.
7. By formula (8.7) to calculate the theoretical value of period $T_{\text{теор}}$
8. Draw conclusion.

Control questions

1. What is physical pendulum?
2. Make and write down differential equation of free harmonic oscillations of the physical pendulum.

3. Write down equation of oscillations, which is the decision of differential equation of physical pendulum. Draw the graph of this equation.
4. How does name sizes which are included in equation of oscillations of the physical pendulum? What to the dimension of these sizes?
5. Write down formulas for a period and cyclic frequency of oscillations of the physical pendulum.
6. Formulate the theorem of Steiner.
7. To get the period of oscillations of hoop in relation to an axis, what perpendicular to his plane passes through it.

Author: V.K. Manko, assistant professor, candidate of physical and mathematical sciences.

Translator: S.P. Lushchin, assistant professor, candidate of physical and mathematical sciences.

Reviewer: S.V. Loskutov, professor, doctor of physical and mathematical sciences.

9 LABORATORY WORK № 44 MECHANICAL FREE DAMPED OSCILLATIONS

THE AIM is to determine the logarithmic decrement and the damping factor of mechanical oscillations.

INSTRUMENTATION AND APPLIANCES: spring pendulum, stop-watch, set of loads.

9.1 Short theory

Oscillatory motion of mechanical system, as a rule, occurs in the presence of friction, resulting in the transformation of mechanical energy of oscillations into heat. Ideal oscillations will continue forever without change in amplitude. Friction, however, produces damped oscillations. In this case it is possible to write the displacement equations in the form

$$x = A \cos \omega t, \quad (9.1)$$

but A is understood to decrease with time.

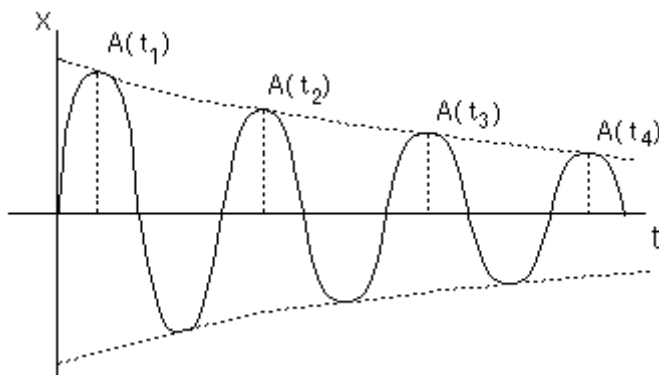

Figure 9.1

To determine in what a way $A(t)$ depends on time, the frictional force must be known for every instant of time during which oscillations occur. A simplifying assumption is that the frictional force is proportional to the velocity of motion

$$f_{fr} = -r v \quad (9.2)$$

where the coefficient r is known as the resistance constant.

In the presence of friction the oscillating body is under the action of two forces:
restoring force

$$F = -kx = -m\omega_0^2x \quad (9.3)$$

and the force of friction

$$f_{fr} = -rv \quad (9.4)$$

Applying Newton's second law we obtain:

$$ma = -kx - rv \quad (9.5)$$

By substitution, it is not difficult to show that this equation is satisfied by the equation

$$x = A_0 e^{-(r/2m)t} \cos \omega t. \quad (9.6)$$

Here, A_0 is the amplitude at the instant of time $t = 0$.

It should be noted that the ratio of two successive amplitudes is a constant. Thus, the expressions for the amplitude after $(n-1)$ and n periods, respectively, are

$$A_{n-1} = A_0 e^{-(r/2m)(n-1)T} \quad (9.7)$$

$$A_n = A_0 e^{-(r/2m)nT}$$

Let us divide the former relation by the latter. The ratio

$$\frac{A_{n-1}}{A_n} = e^{\frac{r}{2m}T} \quad (9.8)$$

does not depend on n . The rate of damping is sometimes expressed by the logarithmic decrement λ

$$\lambda = \ln \frac{A_{n-1}}{A_n} = \frac{r}{2m}T \quad (9.9)$$

Calculate the velocity and acceleration of motion expressed by the formula

$$v = \frac{dx}{dt} = x_0 e^{-\beta t} (\cos \omega t - \sin \omega t), \quad (9.10)$$

$$a = \frac{dv}{dt} = x_0 e^{-\beta t} (-\omega \sin \omega t - 2\beta \omega \cos \omega t + \beta^2 \sin \omega t). \quad (9.11)$$

Then we obtain

$$(-m\omega^2 + m\beta^2 + k - r\beta) \sin\omega t + (2m\beta\omega - r\omega) \cos\omega t = 0$$

This equation holds good at any instant (at any combinations of $\sin\omega t$ and $\cos\omega t$), which is possible if the coefficients before sine and cosine equal zero. Then

$$2m\beta = r; \quad m(\omega^2 + \beta^2) = k = m\omega_0^2; \\ \omega = \sqrt{\omega_0^2 - \beta^2} \quad (9.12)$$

Here ω is the frequency of damped oscillations.

9.2 Experimental part

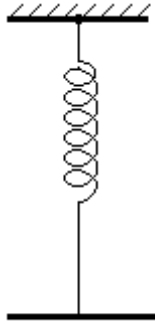

Figure 9.2

The logarithmic decrement of the damping oscillation is

$$\lambda = \ln \frac{A_n}{A_{n+1}} = \ln \frac{A(\tau)}{A(\tau+T)} = \ln \frac{A_0 e^{-\beta\tau}}{A_0 e^{-\beta(\tau+T)}}$$

The average of the logarithmic decrement is given by

$$\lambda_{av} = \frac{1}{4} \left(\ln \frac{A_1}{A_2} + \ln \frac{A_2}{A_3} + \ln \frac{A_3}{A_4} + \ln \frac{A_4}{A_5} \right) = \frac{1}{4} \ln \frac{A_1}{A_5}$$

The damping factor is

$$\beta = \frac{\lambda_{av}}{T} \quad (9.13)$$

1. Make the spring pendulum in oscillation motion.
2. Measure the amplitudes of first - A_1 and of fifth - A_5 oscillations.
3. Calculate the period of vibration by the formula

$$T = t/n, \quad (9.14)$$

where t is the time of " n " oscillations ; " n " is the number of oscillations.

4. Calculate the logarithmic decrement and the damping factor in accordance with the relations

$$\lambda_{av} = \frac{1}{4} \ln \frac{A_1}{A_5}; \quad (9.15)$$

$$\beta = \frac{\lambda_{av}}{T} \quad (9.16)$$

5. Calculate $\Delta\lambda/\lambda$, $\Delta\beta/\beta$, $\Delta\lambda$ and $\Delta\beta$ for five measurements. Calculate the half-width of the confidence interval for A_1 , A_5 and t using the main errors of measurements.
6. Put down the date of measurements and the results of calculation in the table 9.1.
7. Repeat the measurements for another mass.
8. Put down the date of measurements in table 9.1.
9. Make analyses of the experimental results.

Table 9.1

N	A_1 , mm	A_5 , mm	t, s	$\frac{\Delta\lambda}{\lambda}$	$\Delta\lambda$	$\frac{\Delta\beta}{\beta}$	$\Delta\beta$
1							
2							
3							
4							
5							

Control questions

1. What oscillations is called damped?
2. Write down differential equation of damped oscillations and specify physical value.
3. What law does displacement of damped oscillations change on from time? Write equation of damped oscillations and draw its graph.
4. How does amplitude of damped oscillations depend from time?
5. Give determination and write down expression for logarithmic decrement.
6. What is named times of relaxation?

Author: V.K. Manko, assistant professor, candidate of physical and mathematical sciences.

Translator: S.P. Lushchin, assistant professor, candidate of physical and mathematical sciences.

Reviewer: S.V. Loskutov, professor, doctor of physical and mathematical sciences.

10 LABORATORY WORK № 45 ELECTROMAGNETIC FREE DAMPED OSCILLATIONS

THE AIM is to determine the logarithmic decrement and damping factor of electric oscillations.

INSTRUMENTATION AND APPLIANCES: an electric oscillating circuit, oscillograph.

10.1 Short theory

The processes of transforming electric energy into magnetic energy and vice versa are of fundamental importance in electrodynamics. A simple system in which such transformations occur is a charged electric condenser whose plates are connected at a certain instant to a coil. When the condenser discharges, an electric current flows through the coil and creates a magnetic field around it. At each instant, the electric field of the condenser and the magnetic field of the coil are linked.

Let us consider an electric oscillating circuit, i.e. a circuitry consisting of a coil of inductance L and a condenser of capacitance C and the resistance R .

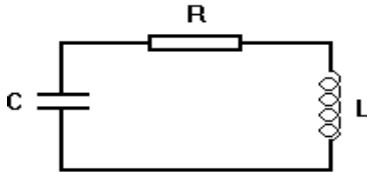

Figure 10.1

The electric current flows through the conductors with a finite velocity. Thus the motion of the charges which begins at some definite time on the condenser plates, reaches the coil at a short time Δt later, where Δt depends on the velocity of propagation of the current and the length of the wires. This means that the current intensity in different parts of the circuit will be different. A change in voltage at the condenser plates does not immediately reach the coil, but at a short time later; in exactly the same way,

the self-induced e.m.f. arising at some fixed time in the coil reaches the condenser a short time after. However, if the dimensions of the circuit are small, then the speed of the change in the current intensity is not very large, then it is reasonable to suppose that the current intensity is the same everywhere in the circuit at a fixed time.

In such a case we may use the second Kirchhoff's Law for a closed circuit: the algebraic sum of all the e.m.f. and the drop in voltage is equal to zero at a given time. This law is true only for constant currents; if the current intensity in the circuit changes, then the application of this law results in a larger error the faster the current changes and the larger the dimensions of the circuit.

The self-induced e.m.f. has a sign opposite to the sign of the potential difference on the condenser plates, so that Kirchhoff's Law is written as

$$V - \varepsilon_{\text{ind}} + IR = 0,$$

$$\text{or } \frac{q}{C} + L \frac{di}{dt} + IR = 0,$$

$$\frac{1}{C} i + L \frac{d^2 i}{dt^2} + R \frac{di}{dt} = 0.$$

At this point, an analogy should be drawn between the corresponding electric and mechanical quantities. Comparing the last equation with the equation for mechanical oscillations with friction, it is seen that the electric resistance is analogous to the resistance coefficient r , which is a measure of the mechanical resistance. We shall simply give the final result of the solution of the last linear differential equation, which incidentally is easily verified by substitution in the above equation:

$$i = i_0 e^{-\beta t} \cos \omega t.$$

The frequency of oscillation is given by

$$\omega = \sqrt{\omega_0^2 - \beta^2}.$$

Thus, the process is determined by two characteristics - the natural frequency of free undamped oscillations

$$\omega_0 = \frac{1}{\sqrt{LC}}$$

and the damping coefficient $\beta = R/2L$. It will be noted that when $\omega_0^2 < \beta^2$, i.e., $4L < CR^2$ oscillations become impossible.

The difference of voltage on the condenser plates varies according to the law

$$U = U_0 e^{-\beta t} \sin \omega t.$$

Then the amplitude of such oscillations is

$$U = U_0 e^{-\beta t} \sin \omega t$$

After logarithming this expression we obtain

$$\ln U_m = \ln U_0 - \beta t.$$

Thus, the damping factor β is equal

$$\beta = \tan \alpha = \frac{\ln U_{ma} - \ln U_{mb}}{t_b - t_a},$$

where α is the angle how it shows Fig.10.2:

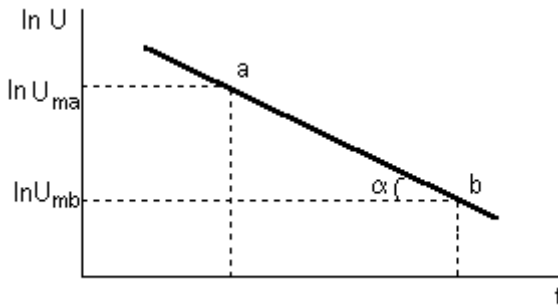

Figure 10.2

The logarithmic decrement we obtain from formula

$$\lambda = \beta T.$$

The electric circuit shown in fig.10.3 may be used to measure the dependence of a difference of voltage versus a time.

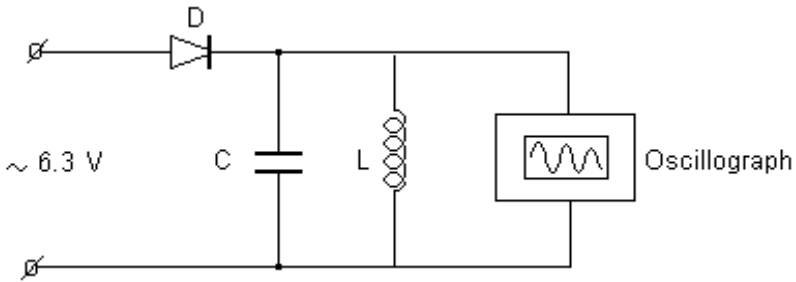

Figure 10.3

10.2 Experimental part

1. Measure the amplitudes of electric oscillations as it is shown in figure 20.4. Put down the values of measurements in table 10.1.

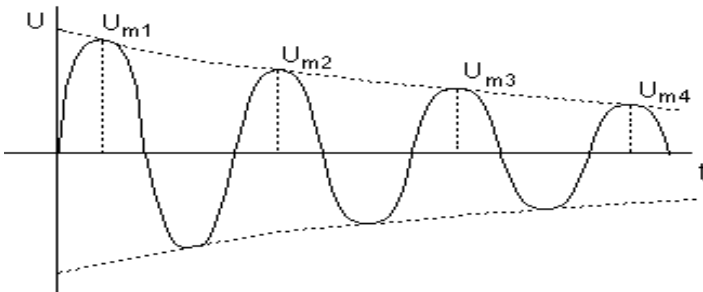

Figure 10.4

2. Put down the metal plate on the inductance. Measure the amplitudes of electric oscillation. Put down the date of measurement in table 10.1.

3. Plot the graph, plotting $\ln U_m$ against a time t for two cases:
- air-core inductance;
 - inductance with a metal plate.

Table 10.1

N	Time in units of period	Time t , s	U_m , mm	$\ln U_m$	β
Air - core inductance					
0	0				
1	T				
2	2T				
3	3T				
Inductance with a metal plate					
0	0				
1	T				
2	2T				
3	3T				

4. Calculate the damping factor and logarithmic decrements for two cases if $T = 0.5$ ms.

5. Make analysis of the experimental results.

Control questions

1. What is damped oscillations?
2. What are the logarithmic decrement and the damping factor?
3. Calculate the velocity and acceleration for damped oscillatory motion.
4. Obtain the expressions for the frequency and period of damped oscillations.

Translator: S.P. Lushchin, assistant professor, candidate of physical and mathematical sciences.

Reviewer: S.V. Loskutov, professor, doctor of physical and mathematical sciences.

11 LABORATORY WORK № 46 RESONANCE IN OSCILLATORY CIRCUIT

Purpose of work: study of forced oscillations and resonance phenomena in an oscillatory circuit.

Task: obtain dependence between voltage u_c on a condenser and frequency ν of the enforced voltage and build a graph $u_c = f(\nu)$. Define resonance frequency ν_0 and check the formula of resonance curve.

Devices and equipment: oscillatory circuit, generator (an output is a 5 Ohm), frequencymeter, millivoltmeter.

11.1 Experimental setting

Variable voltage is produced from the generator (Fig.11.1) to an oscillatory circuit:

$$u(t) = u_0 \cos(\Omega \cdot t), \quad (11.1)$$

where u_0 is the voltage amplitude; Ω - cyclic frequency of generator; u is condenser voltage, measured by millivoltmeter.

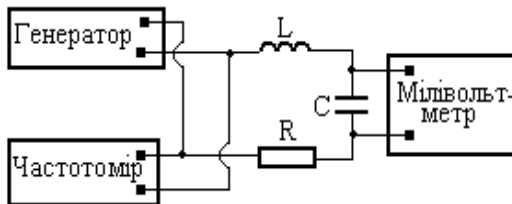

Figure 11.1

11.2 Theoretical part

Forced oscillations appear in the contour when alternating current from an extraneous source (in our case from a generator) is following through serially connected inductance – L , capacity – C and resistance – R .

Differential equation which describes the change of charge on a condenser with time looks like:

$$\frac{d^2q}{dt^2} + 2\beta \frac{dq}{dt} + \omega_0^2 q = \frac{u_0}{L} \cos(\Omega \cdot t) \quad . \quad (11.2)$$

where $\beta = \frac{R}{2 \cdot L}$ - attenuation coefficient; $\omega_0 = \sqrt{\frac{1}{LC}}$ - own cyclic frequency of non-attenuating oscillations in the contour when $R = 0$.

The solution of equation (11.2) is

$$q(t) = q_0 e^{-\beta t} \cos(\omega t + \varphi) + \frac{U_0}{L\rho} \cos(\Omega t - \alpha) \quad , \quad (11.3)$$

where ω is cyclic frequency of free oscillations

$$\rho = \sqrt{(\omega_0^2 - \Omega^2)^2 + 4\beta^2 \Omega^2} \quad , \quad \alpha = \arctg \frac{2\beta \Omega}{\omega_0^2 - \Omega^2} \quad .$$

After some time the first element in equation (22.3) will become infinitely small due to exponent in a negative power. The contour will get into the permanent mode of the forced oscillations with voltage frequency Ω .
Condenser voltage:

$$U_c(t) = U_{oc} \cos(\Omega t - \alpha) = \frac{q(t)}{C} = \frac{U_0}{LC\rho} \cos(\Omega t - \alpha) \quad . \quad (11.4)$$

Amplitude of these oscillations depends on frequency Ω of the enclosed difference of potential

$$U_{oc}(\Omega) = \frac{U_0}{LC\rho} = \frac{U_0}{LC\sqrt{(\omega_0^2 - \Omega^2)^2 + 4\beta^2 \Omega^2}} \quad . \quad (11.5)$$

This function has an extremum (max) at frequency

$$\Omega_p = \sqrt{\omega_0^2 - 2\beta^2} \quad , \quad (11.6)$$

which is named **resonance frequency**. Consequently, the phenomenon of resonance consists in achieving of maximal amplitude of the forced oscillations at the change of frequency of external action. Resonance frequency does not coincide with the own frequency of oscillations ω_0 as shown in (11.6).

From Fig. 11.2 it is evident that voltage higher than the amplitude of the enclosed signal appears at two values of frequency.

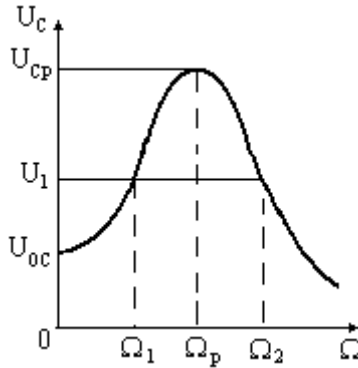

Figure 11.2

From (11.5):

$$\frac{U_o}{LC\sqrt{(\omega_o^2 - \Omega_1^2)^2 + 4\beta^2\Omega_1^2}} = \frac{U_o}{LC\sqrt{(\omega_o^2 - \Omega_2^2)^2 + 4\beta^2\Omega_2^2}}.$$

After simplifications obtain a correlation which enables to calculate resonance frequency by a value Ω_1 and Ω_2 for any voltage $U > U_{oc}$

$$\Omega_p = \sqrt{\frac{\Omega_1^2 + \Omega_2^2}{2}}. \quad (11.7)$$

11.3 Experimental part

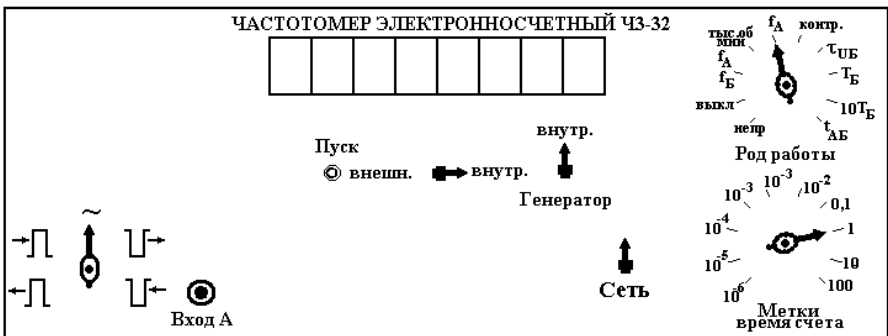

Figure 11.3

1. Assemble the scheme according to figure 11.1. The working point of the frequencymeter is point A (see Fig. 11.3). Initial resistance of the generator is 5 Ohm.
2. Set all the switches on the front panel of frequencymeter to positions shown on fig 11.3.
3. Set a measuring limit 7,5 V on the millivoltmeter by turning the switches.
4. Switch on generator and frequencymeter.
5. Select frequency multiplier $\times 100$ and set voltage = 10 V on the generator.
6. Changing the frequency of the generator, find the experimental value of the resonance frequency and voltage at resonance. Write down these values in a table 11.1.
7. Measure a resonance curve, i.e. dependence of voltage on the condenser U_C from frequency, in a range from 6 kHz to 17 kHz. Thus fluently increasing frequency observer the values on the millivoltmeter. When voltage will change on approximately 1 V (20 marks), write down the value of frequency and voltage in a table. It is not necessary to try to get the exact meaning of voltage, as the regulator of frequency of generator is rough and attaining it is impossible.

Table 11.1

Ω, kHz																			
U_C, mV																			

8. Draw the resonance curve on a plotting paper based on experiment results.
9. Choose 5 values of voltage on the condenser and for each of them ind frequencies Ω_1 and Ω_2 on the resonance curve (see fig.11.2). Write down results in a table 11.2.

Table 11.2

Ω_1, kHz						
Ω_2, kHz						
Ω_p, kHz						

10. Using formula (11.7) calculate five values of resonance frequency Ω_p and put them into the table 22.2. Find the mean value of the resonance frequency.
11. Analyze the results, confronting a calculation ($\Omega_{p, \text{ПОЗР.}}$) and directly measured ($\Omega_{p, \text{ЭКСТ}}$) resonance frequencies. If they appear approximately identical, then it justifies the correlation (11.7), and consequently expression (11.5) of resonance curve.

Control questions

1. What oscillations are named forced?
2. Write down differential equation of the forced oscillations in a contour.
3. What is called permanent mode of the forced oscillations?
4. How does voltage on a condenser depend from time in permanent mode of the forced oscillations?
5. What is resonance curve? Write down its analytical kind.
6. Write down expression for resonance frequency.
7. Obtain correlation (11.7).

Author: V.K. Manko, assistant professor, candidate of physical and mathematical sciences.

Translator: S.P. Lushchin, assistant professor, candidate of physical and mathematical sciences.

Reviewer: S.V. Loskutov, professor, doctor of physical and mathematical sciences.

12 LABOR SAFETY REGULATION №62 DURING WORKING IN PHYSICS LABORATORY

12.1 General provisions

12.1.1 People who are allowed to work in the laboratory:

- members of the department who know their functional responsibilities and have an access to the independent work;
- students who have learnt behavior rules in the lab, who know methods of the performance of the laboratory work and who are well instructed.

12.1.2 Briefing is performed by the member of the department. Every student must confirm his knowledge of the briefing with his personal signature in journal 'Labor safety regulation of students'

12.1.3 Teacher permits students to work in the lab after checking of their knowledge level of the methods of laboratory works performing.

12.2 Safety requirements before starting work

12.2.1 Only instruments in good working condition are used.

12.2.2 Before starting work teacher must check the working condition of the devices and then permit to work.

12.2.3 People who don't take part in the laboratory work don't have an access to the lab.

12.3 Safety requirements during laboratory work

12.3.1 It's not allowed to turn on or turn off the sources of the electrical or light energy without permission of the teacher.

12.3.2 It's not allowed to turn different screws, press any buttons, switches without permission of the teacher.

12.3.3 Students must immediately inform the teacher about all shortcomings of the devices

12.4 Safety requirements after finishing the work

12.4.1 Before finishing the work student must consecutively turn off all devices.

12.4.2 Student must check by sight serviceability of the devices. It's necessary to remember that student is responsible for the broken-down devices.

12.5 Safety requirements in case of emergencies

12.5.1 Student must:

- stop working;
- turn all devices off;
- inform teacher about what has happened in the lab.

12.5.2 In case of the fire student must begin to extinguish a fire with available means.

12.5.3 Teacher must call the number 9-101 and notify about accident.

References

1. Савельев, И. В. Курс общей физики, т.1 / И.В. Савельев. - М.: Наука, 1986. - 432 с.
2. Трофимова, Т. И. Курс физики / Т.И. Трофимова. - М. : Высшая школа, 1990.-478с.
3. Чолпан, П. П. Фізика / П.П. Чолпан. - К. : Вища школа, 2003.- 568 с.
4. Gevorkjan, R. G.. A Course of General Physics / R.G. Gevorkjan, V. V. Shepel. –Moscow : Higher School, 1967.-550 p.
5. Koshkin, N. I., Handbook of Elementary Physics / N.I. Koshkin, M.J. Shierikevich. –Moscow : Mir Publishers, 1977.-272 p.
6. Kireev, P. S. Semiconductor Physics / P.S. Kireev. – Moscow : Mir Publishers, 1974.-672 p.
7. Грехов, А. М. Фізика. Навчальний посібник (англ. мовою) / А.М. Грехов. - К. : Вид-во Європ. ун-ту, 2003.-356 с.
8. Англо-русский физический словарь / под ред. Д.М. Толстого. - М. : Советская энциклопедия, 1968. - 848 с.
9. Методичні вказівки до лабораторного практикуму з фізики розділ „Коливання та хвилі”. Частина 1,2. Для студентів інженерно-технічних спеціальностей денної форми навчання. / Укладачі: В.К. Манько, М.І. Правда, С.П. Луцін, С.В. Сейдаметов. - Запоріжжя: ЗНТУ, 2009.