

MINISTRY OF EDUCATION AND SCIENCE OF UKRAINE

Zaporizhzhia Polytechnic National University

METHODICAL GUIDES

for laboratory works on course

«FUNDAMENTALS OF ELECTRICAL MEASUREMENT
AND METROLOGY»

students towards the specialty
G3 Electrical Engineering
of all forms of learning

Part 1

2025

Methodical guides for laboratory works on course «Fundamentals of electrical measurement and metrology» students towards the specialty G3 Electrical Engineering of all forms of learning. Part 1. / Set. O.S. Nazarova – Zaporizhzhia: Zaporizhzhia Polytechnic National University, 2025. – 38 p.

Compiler: O.S. Nazarova, docent, c.t.n.

Reviewer: A.V. Pyrozhok, docent, c.t.n.

Responsible for the issue: O.S. Nazarova, docent, c.t.n.

Approved
chair meeting EPA
protocol number 1 on 28.08.2025 p.

Recommended
to the edition by SMC ETF
protocol number 4 on 20.11.2025 p.

CONTENTS

Preface	4
1 Laboratory work №1 Research of properties of electromechanical measuring devices.....	5
2 Laboratory work №2 Expansion of measuring limits of ammeters and voltmeters by means of shunts and additional resistors	15
3 Laboratory work №3 Measuring of power and electrical energy in three-phase circuits.....	23
4 Laboratory work №4 Research of instrument current transformers	31
List of reference sources	41

PREFACE

Methodical instructions contain descriptions of the four laboratory work on discipline «Fundamentals of electrical measurement and metrology» in accordance with the curriculum specialties Bachelor's Degree G3 Electrical Engineering and recommendations for their implementation.

Laboratory work containing brief theoretical information under the theme of work, objectives, recommendations for their implementation and test questions for better learning and verifying the student knowledge and skills.

For students of specialty G3 Electrical Engineering of all forms of learning.

1 LABORATORY WORK №1

Research of properties of electromechanical measuring devices.

Aim of work: is to study structure and principle of action of measuring mechanisms of the different systems, investigate influence of frequency and form of periodic signal on the readings of devices.

Program of work.

Study of operation principle and construction of electromechanical measuring devices.

Research of influence of frequency of voltage that is measured, on the error of devices of the different systems.

Investigation of voltage curve influence on readings of devices of different systems.

Investigation of consumed power and internal resistance of devices of different systems

Treatment of results and arrangement of report.

Short theoretical information.

Electromechanical measuring device consists of measuring circuit, measuring mechanism and reading device. Measuring mechanism (MM) consists of immovable and movable systems. Generally immovable and movable parts of MM can contain current circuits, electrically charged bodies, permanent magnets etc.

Electrical energy of such system:

$$W_E = \frac{1}{2}L \cdot I^2 + \frac{1}{2}C \cdot U^2 + M_{12} \cdot I_1 \cdot I_2, \quad (1.1)$$

where L is total inductance of the circuits; M_{12} is mutual inductance of movable and immovable circuits; C is electrical capacity of charged bodies.

Magnetically-electrical measuring device is shown on the Figure 1.1. it's immovable system is build up by a permanent magnet 1 with pole extensions 2 and core 3 from magnetically soft steel. Movable part is the frame 4 consists of copper wire wounded around aluminums frame. The frame is fixed with two half-axes 5, that are free to rotate around «kerns». The half-axes are rigidly joined with extensions of springs 6 made of beryl bronze, which are used to create counteracting moment. The arrow 7 is

joined to one of half-axes, and couple with scale 9 it creates the reading device. Counterbalances 8 increases moment of inertia of movable system and in couple with quitter of vibrations damp oscillations of movable system.

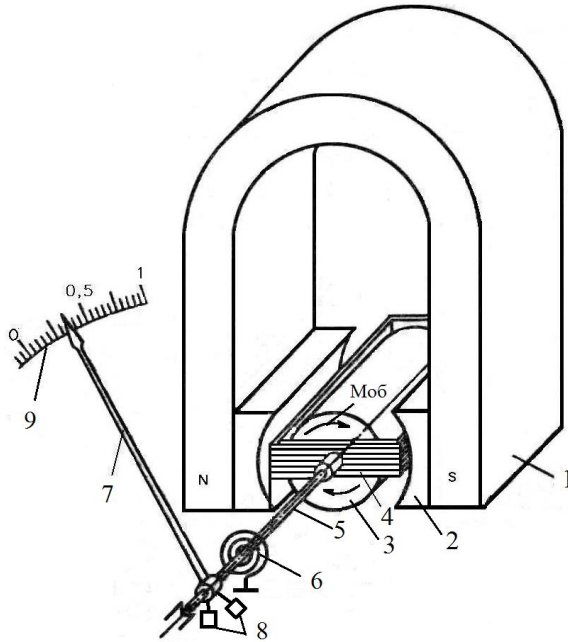

Figure 1.1 – Magnetically-electrical mechanism.

The ends of the frame are connected to half-axes and through them with springs. Measuring value is direct current I which is penciled to the spring. As far as frame is located in magnetic field of the permanent magnet the couple of forces acts on it during current passing through the frame and it creates moment [1]:

$$M_{\text{о}6} = B \cdot S \cdot n \cdot I \cdot \sin \alpha , \quad (1.2)$$

where B is induction of magnetic field; S is square of frame; N is number of turns; I is current flowing through the frame; α – is angle between vector of magnetic induction and perpendicular to the frame plane. Counteracting moment is directed towards the rotating moment which increases linearly with increase of rotating angle.

$$M_{np} = G \cdot \alpha , \quad (1.3)$$

where G is specific counteractive moment.

When the equilibrium is set:

$$M_{o6} = M_{np} \quad (1.4)$$

motion of system will stop.

To make the rotating moment independent on frame rotation angle in the gap between poles of the magnet, core 3 is set. Magnetic induction vector B in the gap is directed along the radius of intersection of core and at any angle of frame angle between induction vector and perpendicular of frame plane equals 90 degrees. Then from (1.2) and (1.3) follows:

$$\alpha = \frac{1}{G} B \cdot S \cdot n \cdot I. \quad (1.5)$$

As far as movable system of the drive has inertia momentum, then by being moved and shifted by angle α it will oscillate around the equilibrium position for a while. For it being damped, in measuring equipment oscillation dampers are set (air, hydraulic and magnetically-inductive ones). At devices of magnetically-electric system magnetically-inductive dampers are used. At framework of the frame is a short-circuited conductor. When it is rotated inside magnetic field, EMF is set inside it and Eddy's currents occur. Interaction of Eddy's currents field and field set in gap creates braking moment which damps frame oscillations. The described above device for creation of counteracting moment and counting device are typical ones and are also used in devices of other systems: electrodynamical, electrostatical and electromagnetic. The rotating moment direction in mechanism of magnetically-electrical system depends on direction of current in a frame. That's why devices of magnetically-electrical system without counters are used only for direct current measurement [2].

By analyzing (1.5) it can be concluded that the error of magnetically-electrical device depends on specific counteracting momentum G stability and on magnetic induction's B stability. As well as spring elasticity, induction of magnet's field depends on temperature, then for magnetically-electrical device, temperature error is essential.

This error can be avoided or decreased by inclusion of temperature-compensating circuits into the measuring circle, that is series or parallel connection resistor and termoresistor.

Electromagnetic measurement mechanism (Figure 1.2) contains immovable coil 1 and movable plain or core 2 made of magnetically-soft material, which is fixed with axis 3 or stretches. Axis is rotated at cores on toes 5. Spiral spring 4 is used for creation of counteracting moment. Arrow 6 and scale 7 form reading device. Piston 8 is joined to the terminal of arrow, that is the damper of movable system's oscillations.

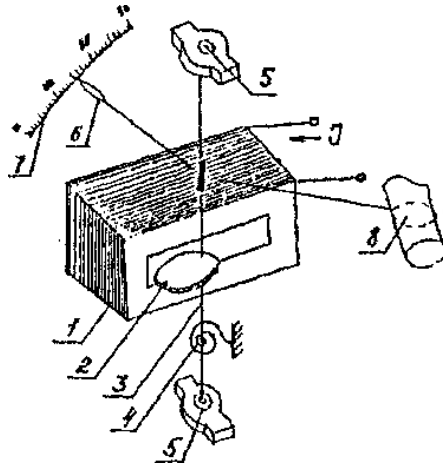

Figure 1.2 – Electromagnetic mechanism.

When current flows through the coil, the core is being drawn inside it and torque acts on the axis:

$$M_{\text{ог}} = \frac{dW_e}{d\alpha} = \frac{d}{d\alpha} \left(\frac{1}{2} LI^2 \right) = \frac{1}{2} I^2 \frac{dL}{d\alpha}. \quad (1.6)$$

Moment M_n counteracts it.

If these moments are equal, movable system stops:

$$\alpha = \frac{1}{2G} \frac{dL}{d\alpha} I^2. \quad (1.7)$$

This equation holds with direct current and rms value of alternating current. The device's scale is non-uniform, but in specific construction types $\frac{dL}{d\alpha} I \approx \text{const}$ and the non-linearity of a scale can be reduced from 20-25% to 0,5-0,2% which makes scale almost uniform.

Hence low magnetization power of the coil and absence of steel magnetic circuits, intrinsic magnetic field of electromagnetic measuring device is weak, that's why external magnetic fields influence it considerably and they may cause error. To reduce this error, measurement device is placed inside a shield or is constructed in an astatic way.

Advantages of electromagnetic measurement devices are construction simplicity, high reliability and overload capability, ability to measure both ac and dc. Drawbacks – not very high sensitivity and relatively low accuracy. Widespread devices have accuracy class 1,5, special designs may reach accuracy class 0,2.

Electrodynamical and ferrodynamical measurement mechanisms and devices are schematically shown on Figure 1.3 (a and b).

Electrodynamical measurement mechanism contains immovable coil 1, which consists of two parts and movable coil 2, which is fixed on axis or by means of stretches in the middle of immovable one. Spiral springs are used to create the counteracting moment and to supply current to the movable coil. When current I_1 and I_2 flows through the coils, interacting magnetic fields are set around them and they create the torque

$$M_{o6} = \frac{dW_e}{d\alpha} = \frac{d}{d\alpha} \left(\frac{1}{2} L_1 \cdot I_1^2 + \frac{1}{2} L_2 \cdot I_2^2 + M_{12} \cdot I_1 \cdot I_2 \right). \quad (1.8)$$

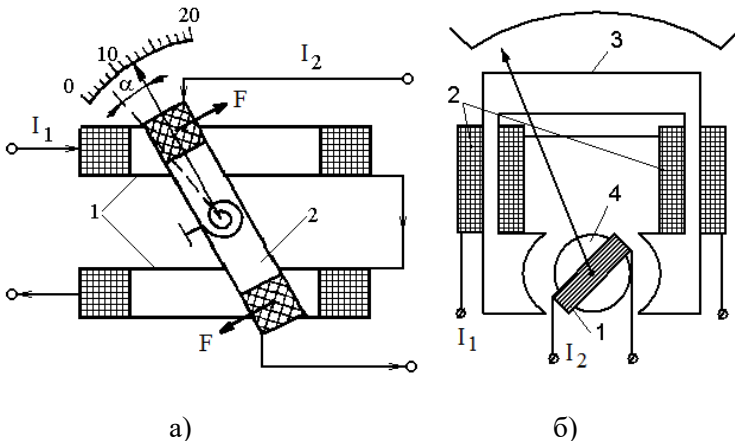

Figure 1.3 – Electrodynamic and ferrodynamical measurement mechanisms.

For direct current:

$$M_{o6} = \frac{dM_{12}}{d\alpha} I_1 I_2. \quad (1.9)$$

For alternating current:

$$M_{o6} = \frac{dM_{12}}{d\alpha} I_1 I_2 \cos \Psi, \quad (1.10)$$

where I_1 and I_2 – rms current values;

Ψ – angle between vectors I_1 та I_2 .

Counteracting moment, created by the springs,

$$M_{np} = G\alpha .$$

In general case:

$$\alpha = \frac{1}{G} \frac{dM_{12}}{d\alpha} I_1 I_2 \cos \Psi. \quad (1.11)$$

Immovable coil in electro-dynamical devices in general case is wound with thicker wire, then the movable one, contains less turns and is connected to the measurement circuit in series; that's why it is called the current coil. Movable coil contains much greater number of turns which are wound by thin wire. In wattmeter's movable coil is connected in parallel with the source or load. That's why it is called the voltage coil.

The scheme of electro dynamical wattmeter is shown on Figure 1.4.

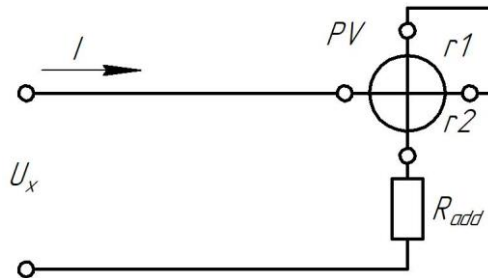

Figure 1.4 – The scheme of electro dynamical wattmeter.

For this scheme on a direct current:

$$\alpha = \frac{1}{G} \frac{dM_{12}}{d\alpha} I^2 = \frac{1}{G} \frac{dM_{12}}{d\alpha} = \frac{U_x^2}{(R_{до6} + r_1 + r_2)^2}, \quad (1.12)$$

$$\text{if } \frac{dM_{12}}{d\alpha} I \approx \text{const}; \quad \alpha = AU_x; \quad \frac{1}{G(R_{\text{доб}} + r_1 + r_2)} = A.$$

Coils size and their mutual disposition are chosen with respect to equation:

$$\frac{dM_{12}}{d\alpha} I \approx \text{const}.$$

Then, starting with 20-25 %, the scale of device is uniform.

Electro dynamical devises are widely used as wattmeter's. Wattmeter's scheme is shown on Figure 1.5.

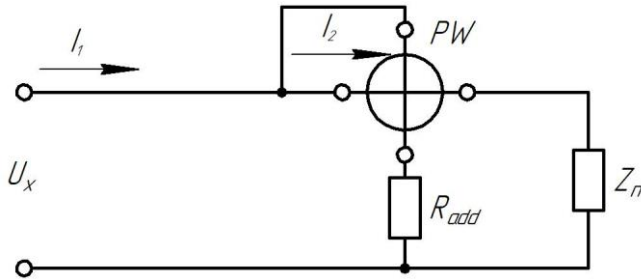

Figure 1.5 – Wattmeter's scheme.

For this scheme:

$$\begin{aligned} i_1 &= i_m; \quad i_2 = \frac{U_x}{R_{\text{add}} + r_2} \approx \frac{U_x}{R_{\text{add}}}. \\ \alpha &= \frac{1}{GR_{\text{add}}} \frac{dM_{12}}{d\alpha} i_m U_x. \end{aligned} \quad (1.13)$$

For alternating current:

$$\begin{aligned} I_1 &= I_m, \quad I_2 = \frac{U_x}{Z_2}, \\ \alpha &= \frac{1}{GZ_2} \frac{dM_{12}}{d\alpha} I_m U_m \cos \varphi = \frac{1}{GZ_2} \frac{dM_{12}}{d\alpha} P. \end{aligned} \quad (1.14)$$

Advantages of electrodynamical devices: high accuracy, ability to operate as ammeters, voltmeters, wattmeters and phase meters (wide functional abilities) with direct or alternating current, properties' stability

with respect to time; disadvantages: lower sensitivity compared to magnetoelectrical system's devices, high inner energy consumption, constructional complicity.

The peculiarity of ferrodynamical devise's system is that immovable coil is placed at magnetic system, movable – in the gap between poles of magnetic system and yoke of magnetically soft steel. For ferrodynamical devises the following ratios holds (1.8)-(1.14), and the scheme on Figure 1.4 and 1.5. Because of the fact, that device contains magnetic system, which magnetic properties depend on temperature and are unsteady in time, ferrodynamical devises have lower accuracy class.

Electrostatic measurement device (Figure 1.6) consists of two pairs of immovable electrodes 1 and movable electrode 2, fixed on axis or stretch. Electrostatic devices are used as voltmeters.

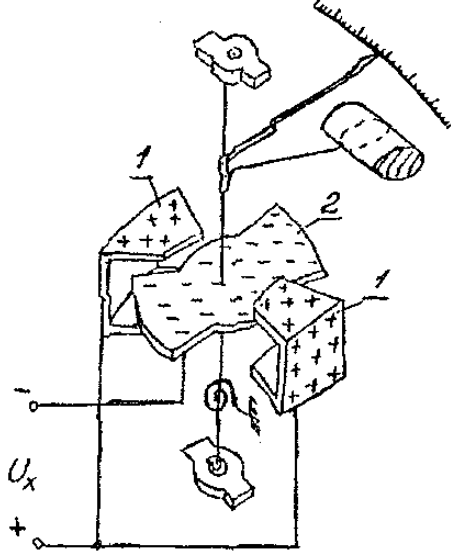

Figure 1.6 – Electrostatic mechanism.

When voltage U_x is supplied to the device, electrical field is set between the electrodes, electrodes are charged and because of charges interaction torque is set, which tries to rotate the system.

$$\alpha = \frac{1}{2G} \frac{dC}{d\alpha} U_x^2, \quad (1.15)$$

where C – capacity of the capacitor, formed by electrodes;
G – specific counteracting moment.

Scale of the device is non-uniform, but with the help of selection of electrodes' shape, dimensions and mutual disposition it is possible to provide scope $\frac{dC}{d\alpha} U_x = \text{const}$ between 20 and 100% of scale.

Inner energy consummation at alternating current is small, at direct is equal to zero. Mentioned above properties of electrostatic voltmeters cause their usage in wide frequency range at low-power circuits of high voltage less than hundreds of kilovolts.

The task.

Make a short synopsis of theoretical material laboratory work, which contains the structure, principle and basic equations of transformation electromechanical measuring instruments of different systems.

Contents of the report of the laboratory work.

The contents of the laboratory work should include the topic, the aim of laboratory work, short theoretical information, conclusions of laboratory work.

Control questions.

1 Construction and operation principle of the magnetoelectric measurement mechanism.

2 Perform static characteristic equation of the magnetoelectric measurement mechanism.

3 How is the counteracting moment set up and what is it equal to at electromechanical measurement mechanisms?

4 What is the purpose of yoke, placed between permanent magnet's poles at magnetoelectric measurement mechanism?

5 Construction and operation principle of magnetically-inductive oscillations damper.

6 Construction and operation principle of electrical measurement devices of straightened system.

2 LABORATORY WORK №2

Expansion of measuring limits of ammeters and voltmeters by means of shunts and additional resistors.

Aim of the work: to cope with methods of calculation and usage of additional resistors and shunts, methods of devices check and notions about measurement errors and their regulation.

Program of the work.

Internal resistance determination by means of voltmeter and additional resistor calculation. Voltmeter check. Results work-out and arrangement of report.

Short theoretical information.

Electromechanical measurement mechanisms at direct connection to measurement circuit has limited range of current and voltage measurement. For example, measurement mechanism of of magnetoelectric system, depending on frame's constructional parameters may have measurement range between 10^{-6} and 10 A or voltage between 10^{-3} and 1 V. In practice, there is necessity to perform measurements in wider range: from 10^{-9} A to 10^6 A and from 10^{-6} V to 10^6 V. To enlarge the measurement range of electromechanical measurement devices scale measuring transformers are used: shunts and additional resistors, voltage divisors and measurement amplifiers, current and voltage transformers [3].

Type of measurement converter is chosen depending on measurement mechanism's system and current or voltage measurement range.

When it is necessary to measure direct current, which is less, then 10 A or more then 7500 A with an ammeter of magnetoelectric, electromagnetic or electrodynamic system, shunts are used. Ammeters with shunts represent millivoltmeters, which measure voltage drop on shunts (Figure 2.1).

Shunt has two pairs of clumps – current ones I-I to be plugged in current circuit; and potential U-U - to plug millivoltmeter, which is calibrated in amperes.

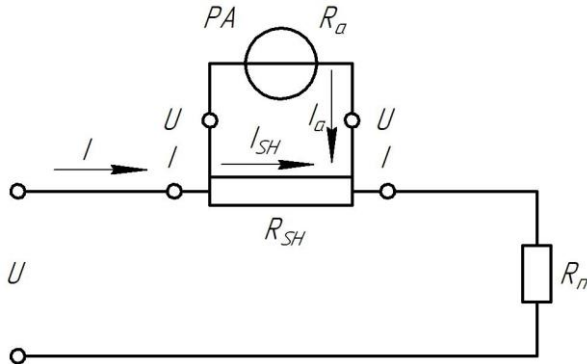

Figure 2.1 – Scheme of devise and shunt connection.

Shunts are made of manganin – alloy of copper, nickel and manganese, that has low temperature resistance coefficient and relatively low specific resistance. To measure low currents (less, then 30 A) shunt is placed in the corps of ammeter. Such shunt is called an internal one. To measure currents less, then 7800 A external shunts are used. When measuring shunt resistance, notions, which flow out from Kirchhoff's laws are used:

$$I = I_A + I_{SH}; \quad I = I_A n; \quad \frac{I_{SH}}{I_A} = \frac{R_{SH}}{R_A}, \quad (2.1)$$

where $I = I_A n$ – upper boundary of measuring of ammeter with shunt;

I_A – upper boundary of measuring of ammeter without shunt.

Consequently from (2.1):

$$R_{SH} = R_A \frac{1}{n-1}, \quad (2.2)$$

where n – number, which shows it in how many times has the measuring limit of ammeter increased with application of shunt.

When shunts are used at alternating current, additional error occurs because of current frequency measurement. That's why shunts are mostly used at direct current with devices of magnetically-electric system. To increase the upper measuring limit of voltmeter additional resistors are used, they are connected to voltmeter in series and in couple they represent voltage divisor (Figure 2.2).

When counting additional resistor resistance, the following correlations are used:

$$U = U_{\text{add}} + U_v; \quad U = nU_v; \quad \frac{U_v}{R_v} = \frac{U_{\text{add}}}{R_{\text{add}}}, \quad (2.3)$$

where U - upper boundary of measuring of voltmeter with additional resistor;

U_v - upper boundary of measuring of voltmeter without additional resistor.

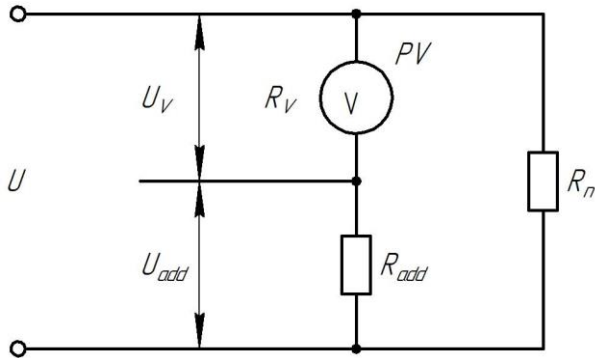

Figure 2.2 – Additional resistance connection.

From (2.3)

$$R_{\text{add}} = R_v(n - 1), \quad (2.4)$$

where n – number, which shows it in how many times has the measuring limit of voltmeter increased with application of additional resistor.

Additional resistors are usually made of manganese wire and used at both AC and DC with devices of magnetoelectric, electromagnetic, and ferrodynamical systems within the frequency to 20 kHz. To reduce the inductance in the manufacture of additional resistors bifilar way winding is used. Accuracy class of standard additional resistors is from 0,01 to 1,0, rated current from 0.5 to 30 mA, boundary voltage - 30 kV.

Measuring devices check

All the measuring instruments that are used have to be verified. Verification - determination of measurement instrument error by

metrological authority and establishing its suitability for use. There are primary and periodic checks: the primary is at issue or after repair of measuring device; periodic - the testing of measurements carried out during its operation and preservation at regular intervals. Contents, methods and means of verification of each type of equipment are to be set by the developer and should be contained in this measurement device manual or in separate instructions [4].

In all cases, testing involves a number of operations, one of which is to determine the basic reduced error of measurement. This error of measurement instrument, used under normal operating conditions. Deviation from normal operating conditions cause additional errors. Normal operating conditions of measurement instrument are indicated in its passport.

Absolute error of measuring device - the difference between the readings and the true value of measuring parameter:

$$\Delta x = x_{\text{II}} - x, \quad (2.5)$$

where x_{II} - instrument readings; x - the real value of measured parameter.

Due to the fact that the true value of the measured value can not be known exactly, in practice actual value of the measured parameter is used instead. During the check the same value measured value X is measured twice: once by the device that is being checked, the second time – by exemplary device. The absolute error is defined as the difference between the readings to be checked and an exemplary unit.

Reduced error of measuring device - is the ratio of the absolute error to the normalizing value. Normalizing value is assumed to be the difference between the highest A_{max} and the lowest A_{min} measure. The reduced error is established to be expressed as percentage. For most devices $A_{\text{min}}=0$, then:

$$\delta_{\text{II}} \% = \frac{\Delta x}{A_{\text{max}}}, \quad (2.6)$$

where δ_{II} - reduced error of the device; A_{max} – upper measurement limit.

The limit of permissible error of measurement device- the biggest (no regard to sign) error of measurement, at which it can be considered as appropriate and permitted for usage.

The limits of permissible error of measurement device are determined by its accuracy class. Class of accuracy of measuring instruments -

a generic characteristic, which is determined by limits of main and additional errors of measuring instruments.

Determination of error at check is carried out not at one point of the peak, but at each label of digital scale, changing the measurement value from the lower to the upper limit, and then - from upper to lower. As a result a series of values of absolute error of this device is obtained: $\Delta x_1, \Delta x_2, \dots, \Delta x_n$ one of which is the largest (without regard to sign).

Accuracy class of the checked device is set by the largest reduced error:

$$\delta_{\text{imax}} \% = \pm \frac{|\Delta x_{\text{max}}|}{A_{\text{max}}} 100 \leq K. \quad (2.7)$$

If the obtained value δ_{imax} is less, then K value of the given device, then the unit under this parameter meets the requirements of inspection and may be found suitable.

With the growth and decay of measuring value in the same point of the scale you can get different readings, the biggest difference between the indications in the same point of the scale of growth and decrease is called the variation (v). For some devices the variation is normalized metrological characteristics and is determined it during testing.

One of the main requirements of the test is that the accuracy class of exemplary device should be greater, then accuracy class of inspected device of least at 2 orders. For example, if the tested instrument is class 1.5 accuracy, the exemplary unit should have accuracy class not lower than 0.5.

Instruments and equipment

The list of instruments and equipment is presented in table 2.1.

Table 2.1 – Instruments and equipment

Name of device	Type of device	Accuracy class	Features
Voltmeter	3-30	1.5	0-50 V
Voltmeter	3-59	0.5	0-75-150-300-600 V
Shop of resistances	P517	0.1	0,01-10 ⁴ Om
Autotransformer	Laboratory	-	

The task.

Set the scheme according to Figure 2.3, which adopted the following notation: R_m – shop of resistances; PV_0 – exemplary voltmeter; PV_x – tested voltmeter.

Determine the internal resistance of the voltmeter being checked. For that, adjusting the voltage with LATR, set the voltage 80-100 V at voltmeter PV_0 . By adjusting the resistance R_m , set PV_x voltage equal to half of U_0 . According to the formula (2.4) internal resistance of voltmeter will be equal to R_v .

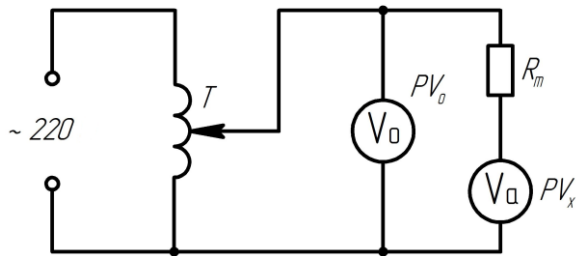

Figure 2.3 – Laboratory work scheme.

Select $n = 2, 3, 4 \dots$ as directed by the teacher and identify additional resistance by (2.4). Set the found resistance R_{n06} on the resistance box.

Check the voltmeter PV_x with the additional resistance connected to it in the next way. Regulating voltage with LATR, set the checked voltmeter arrow, sequentially at each digitized tag peak, first increasing the voltage from zero to the upper limit, and then reducing to zero. It should be followed that the arrow has to fit the appropriate scale marks from one side only. With the exemplary voltmeter, measure the actual measured voltage on these labels. Record the results in table 2.2.

Table 2.2 – Measured results

Measured		Calculated				
Readings PV_x, V	Readings PV_0, V	$\overrightarrow{\Delta x} =$	$\overleftarrow{\Delta x} =$	$\overrightarrow{\delta_n}, \%$	$\overleftarrow{\delta_n}, \%$	$v = \overrightarrow{\Delta x} - \overleftarrow{\Delta x}$
	$\overrightarrow{x_0}$	$\overleftarrow{x_0}$	$x_n - x_0$	$x_n - x_0$		

Construct a graph of dependence of the amendment on device readings.

Compare the highest reduced error (with respect to sign) with the limit of acceptable error of the device to be checked and make conclusion about the suitability of its usage.

Contents of the report of the laboratory work.

The contents of the laboratory work should include the topic, the aim of laboratory work, short theoretical information, laboratory setup scheme, filled table 2.1 and 2.2, the calculations, graph of the amendment of device readings, conclusions of laboratory work.

Control questions

1 Purpose, Structure and switch circuit of shunt. How to calculate the resistance of shunt?

2 Purpose, Structure and switch circuit of additional resistor. How to calculate the resistance of additional resistor?

3 Why usage of shunts is limited at AC?

4 There are two ammeters, one of which with a known internal resistance, the other is unknown. How should the ammeters be connected to a circle, to find the resistance of another ammeter?

5 There is a voltmeter with unknown internal resistance and a resistor of known resistance. How to determine resistance voltmeter?

6 What is the relative reduced error of measuring device? What is an absolute error?

7 How to determine the limit of permissible absolute error of the device if its class of accuracy is known?

8 What is an instrument check and how is it carried out?

9 What is the variation?

3 LABORATORY WORK №3

Measuring of power and electrical energy in three-phase circuits.

Aim of the work: to learn and practice the methods of measuring active and reactive power in three-phase power circuits. Obtaining skills of making up schemes of connection of wattmeter and energy meter.

Program of the work.

Introduction to the workplace. Measuring: active power by method of one device; active power by two devices method; reactive power by method of one device; reactive power by two devices method.

Short theoretical information.

Instantaneous power of three-phase system equals the sum of powers of individual phases (Figure3.1).

$$P = P_A + P_B + P_C = U_A I_A + U_B I_B + U_C I_C. \quad (3.1)$$

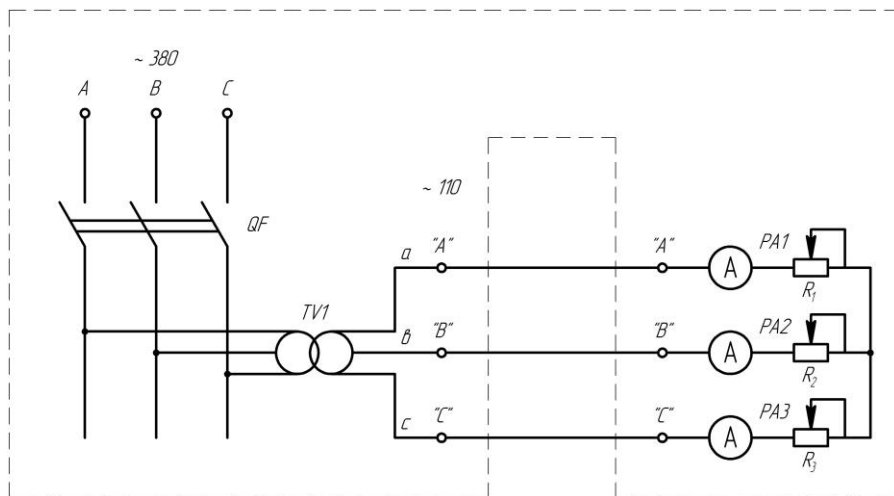

Figure 3.1 – Laboratory work scheme.

At uniform loading of phases active or average power of three-phase system equals to the sum of active powers in separate phases.

$$P = \frac{1}{T} \int_0^T p dt = 3P_{ph} = 3U_{ph}I_{ph} \cos \varphi = \sqrt{3}UI \cos \varphi, \quad (3.2)$$

where U, I - line voltage and current;

φ - phase shift angle between phase voltage and phase current.

Active energy at time t_2-t_1

$$W = \int_{t_1}^{t_2} P dt = Pt. \quad (3.3)$$

Reactive power is defined as sum of jet reactive powers of individual phases:

$$Q = 3U_{ph}I_{ph} \sin \varphi = \sqrt{3}UI \sin \varphi. \quad (3.4)$$

Full power at a symmetrical load of phases:

$$S = \sqrt{P^2 + Q^2} = 3U_{ph}I_{ph} \sin \varphi = \sqrt{3}UI \quad (3.5)$$

Power factor of three-phase system with symmetrical load and sinusoidal voltage:

$$\alpha = \cos \varphi = \frac{P}{S}.$$

In equation (3.1) on the basis of the first Kirchhoff law we can eliminate one of the currents and provide instantaneous value of power through the line voltage in three forms:

$$P = U_{AC}i_A + U_{BC}i_B; \quad (3.6)$$

$$P = U_{AB}i_A + U_{CB}i_C; \quad (3.7)$$

$$P = U_{BC}i_B + U_{CA}i_C. \quad (3.8)$$

Thus, the instantaneous power of three-phase system can be presented as a sum of only two components. Equation (3.1) - (3.6) permit to use one, two or three instruments (meter or wattmeter) for measuring power and energy. Wattmeter is an electromechanical multiplier of current and voltage. Moving part of its measuring mechanism rotate on an angle, proportional to the average instantaneous power, that it measured [5].

Readings of wattmeters are generally defined by the product of current flowing through its series winding to the voltage attached to its parallel circuits, and the cosine of angle between vectors of current and

Active power of three-phase system is defined as the sum of wattmeter readings in two positions of switch:

$$P_{\Sigma} = P_{W1} + P_{W2}$$

In accordance with the enabling circuit diagram (Figure 3.2) we define:

$$P_{W1} = I_A U_{AB} \cos \beta_1$$

$$P_{W2} = I_A U_{AC} \cos \beta_2$$

$$\begin{aligned} P_{W1} + P_{W2} &= IU [\cos(30^\circ + \varphi) + \cos(30^\circ - \varphi)] = \\ &= IU (\cos 30^\circ \cos \varphi - \sin 30^\circ \sin \varphi + \cos 30^\circ \cos \varphi + \sin 30^\circ \sin \varphi) = \\ &= 2IU \cos 30^\circ \cos \varphi = \sqrt{3}UI \cos \varphi = P. \end{aligned}$$

Method of two wattmeters for measuring of active power is used in asymmetric three-phase circuits based on (3.6) - (3.8) by one of the three schemes (Figure 3.3). Active power is defined as the algebraic sum of readings P_{w1} wattmeter and P_{w2} :

$$P_{\Sigma} = P_{W1} + P_{W2} \quad (3.11)$$

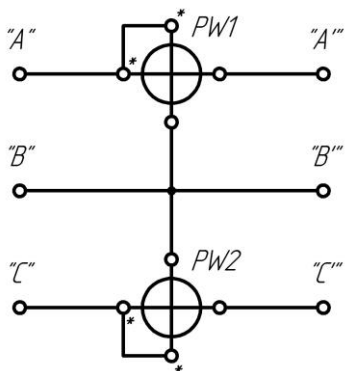

a)

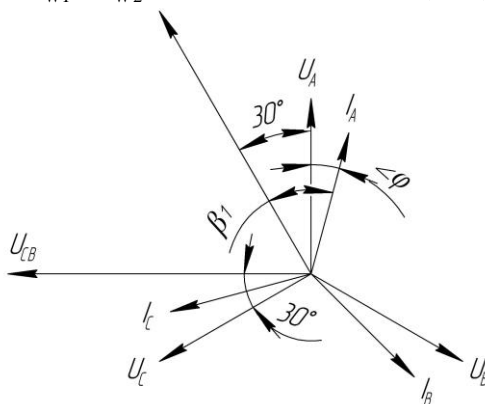

b)

Figure 3.3 – Circuit Diagram (a) and Vector Diagram (b) for Measuring Active Power Using the Two-Instrument Method.

The method of one device for measuring reactive power is used in symmetric circuits using wattmeter connection circuit shown on Figure 3.4.

Reactive power of three-phase system through wattmeter readings:

$$Q = \sqrt{3}P_W .$$

Indications of wattmeter in the scheme (Figure 3.4) considering vector diagram can be written as:

$$P_W = I_A U_{BC} \cos \beta = I_A U_{BC} \cos(90^\circ - \varphi) = IU \sin \varphi .$$

Since reactive power of the system (3.4):

$$Q = \sqrt{3}IU \sin \varphi ,$$

then through the voltmeter readings:

$$Q = \sqrt{3}P_W . \quad (3.12)$$

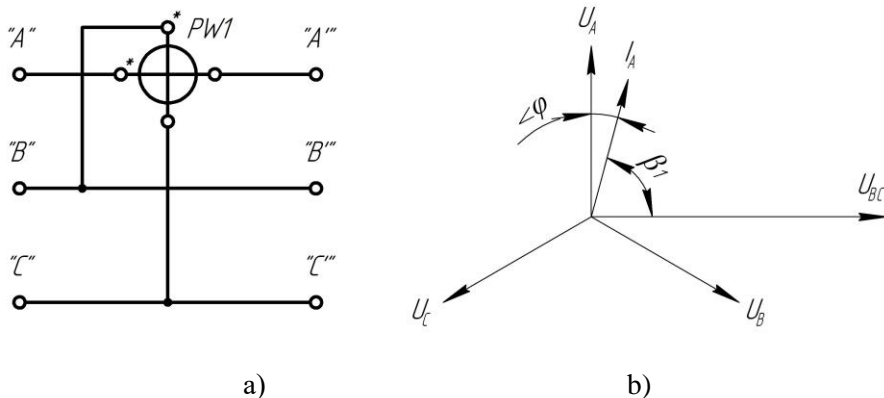

Figure 3.4 – Circuit Diagram (a) and Vector Diagram (b) for Measuring Reactive Power Using the Single-Instrument Method.

Method of two devices for measuring reactive power is used in three-phase circuits with negligible asymmetry. Wattmeter's connection is performed according to the scheme depicted in Figure 3.5.

Reactive power is determined based on a connection circuit and vector diagrams (see Figure 3.5) through the wattmeter readings:

$$Q = \frac{\sqrt{3}}{2} (P_{W1} + P_{W2}) . \quad (3.13)$$

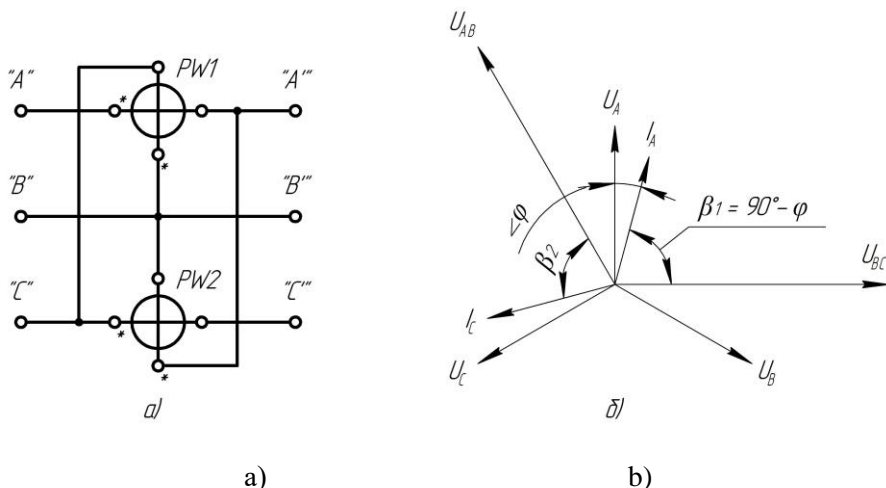

Figure 3.5 – Circuit Diagram (a) and Vector Diagram (b) for Measuring Reactive Power Using the Two-Instrument Method.

The method of the three devices is used for measuring active and reactive power in the three-phase circuits with asymmetry, including the four-wire system. Measurement of active and reactive power in three phase circuits is performed by means of two-element (or three-phase) induction meters. The counters are connected according to wattmeters connection circuit [6].

Devices and equipment

The list of instruments and equipment listed in the table 3.1.

Table 3.1 – List of Instruments and Equipment.

Marking in a scheme	Name of device	Type of device	Accuracy class	Features

The task.

Review stand, measuring circuits and devices on work-place.

Connect three-phase energy meter according to scheme Figure 3.1. Reset pulse remote counter readings by pressing red button. After the entire program execution determine the number of consumed energies.

Set up scheme, Figure 3.2 switch on wattmeter after the counter. Set the load current on the stand $I_A=I_B=I_C$ equal 3A, 4A or 5A, using the handles of resistors R1... R3... Measure line voltage on load by voltmeter. Record the results of all measurements in the table 3.2.

Set up scheme Figure 3.3. Make measurements and record them in table 3.2.

Set up scheme Figure 3.4. Make measurements and write them in the table 3.2.

Set up scheme Figure 3.5. Make measurements and write them in the table 3.2.

According to the results of measurements calculate active and reactivepower, and $\cos\varphi$ for each circuit.

Make conclusions based on experimental data.

Table 3.2 – Results of Measurements and Calculations.

Method of measurement	Measured				Calculated		
	$U_{AB},$ V	$I_{ph},$ A	$P_{w1},$ Wt	$P_{w2},$ Wt	P, Wt	Q, VA	\cos φ
Method of one device:							
measuring P							
measuring Q							
Method of two devices:							
measuring P							
measuring Q							

Contents of the report of the laboratory work.

The contents of the laboratory work should include the topic, the aim of laboratory work, short theoretical information, laboratory setup scheme, filled table 3.1 and 3.2, the calculations, conclusions of laboratory work.

Control questions.

1 By wattmeters of which systems can power of AC and DC be measured?

2 Which methods can be used to calculate $\cos\phi$ in this work?

3 How to determine the upper limit of measurement of wattmeter, unit value and the maximum error that allowed, in watts?

4 In which case the method of one, two and three-phase devices are used in three-phase circuits?

5 Why according to scheme Figure 3.3 with symmetrical load by the readings of two power meter active and reactive power can be determined?

4 LABORATORY WORK №4

Research of instrument current transformers.

Aim of work: the study of current and voltage transformers and how they are connected. Introduction to the verification method of instrument current transformers.

Program of work.

Introduction to the workplace. Demagnetization of current transformers. Check of the investigated current transformers. Research of idling rate of current transformers.

Short theoretical information.

Instrument transformers of current and voltage are purposed for conversion of high alternating currents and voltages into lower ones, suitable for measurement, and also for separation of measurement devices circuits from high voltage circuits. With the help of transformers, devices with low rated current and voltage (ex: 5A and 100V) at high voltage circuits with high currents can be used [7].

Unlike common power transformers, instrument transformers operate at boundary modes: current transformer – in the mode, close to short circuit mode; voltage transformer – to idling rate. Instrument transformer contains magnetic system and two windings – primary one (with W_1 number of turns) and secondary one (with W_2 number of turns). Primary winding of current transformer is connected in series with load Z_H in the circuit; and primary winding of voltage transformer – in parallel with load or line (Figure4.1) Secondary circuit of current transformer is connected to ammeters, current windings of wattmeters and counters, relay and control circuits; in voltage transformer secondary winding is connected to voltmeters, parallel circuits of wattmeters and counters.

In standard current transformers terminals of primary winding are marked as $J1$ and $J2$, and secondary winding terminals - $U1$ and $U2$. In voltage transformers primary winding terminals are marked as A and X , secondary ones – as a and x . In current transformers primary current I_1 is greater then the secondary one I_2 , that's why primary winding has less turns, then secondary one and is made of thick wire or copper bus.

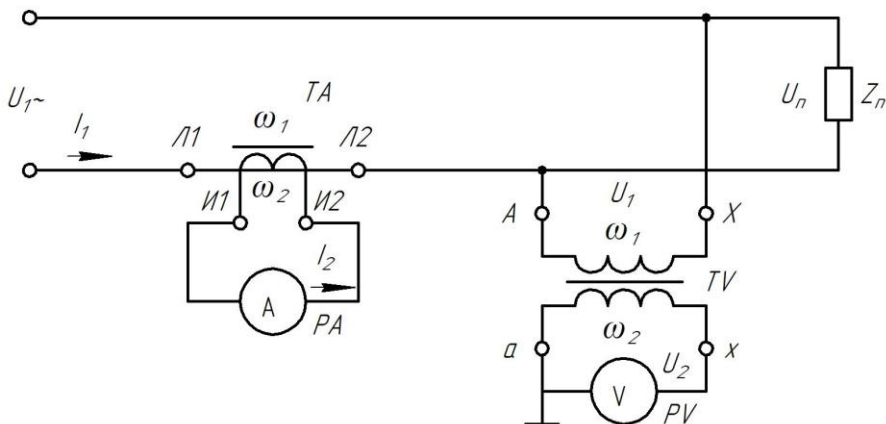

Figure 4.1 – Connection Diagram of Current and Voltage Transformers.

Secondary rated current may be 1A; 2A; 2,5A; 5A with $I_{1n} = 0.8A \dots 40 \text{ kA}$. In voltage transformers primary winding U_1 is greater than secondary U_2 , that's why $\omega_1 > \omega_2$, both windings are made of relatively thin wire. Secondary rated voltage U_{2n} may equal 100V, 150V, $100/\sqrt{3} \text{ V}$, $100/\sqrt{3} \text{ V}$ at $U_{2n} < 750 \text{ kV}$.

According to purpose, instrument transformers are divided into laboratory ones and stationary ones. Laboratory transformers are multiranged ones, have various values of primary values and one or few values of secondary values and have accuracy class: 0,01; 0,02; 0,05; 0,1; 0,2 – for current transformers; 0,05; 0,1; 0,2; 0,5 - for voltage transformers.

Instrument current transformers operate at mode, close to short circuit mode, because resistance of ammeter, which is loaded is extremely small (ex: 0,01 Ohm).

Line measured current:

$$I'_1 = \frac{I_{1n}}{I_{2n}} I_2 = K_{In} I_2, \quad (4.1)$$

where K_{In} – nominal transformation ratio for the current;

I_2 – current, shown by ammeter in secondary circuit.

Rated current transformation coefficient value:

$$K_{In} = \frac{I_{1n}}{I_{2n}}. \quad (4.2)$$

Is shown on its case and in passport data.

The actual value of current in the line:

$$I_1 = K_I I_2,$$

where K_I - actual transformation coefficient, equals I_1/I_2

Actual transformation coefficient - is the unknown value, which depends on the operation mode, i.e. the values of currents and voltages, the nature and magnitude of resistance load current frequency and so on.

Relative error, which occurs because of actual and rated transformation disparity is called the current error:

$$\beta_I = \frac{K_{In} - K_I}{K_I} 100\% = \frac{I_1' - I_1}{I_1} 100\% \quad (4.3)$$

In an ideal transformer without losses, the vector of the secondary current I_2 , shifted in phase relative to the primary current vector I_1 by 180. Angle δ is called the angular error of the transformer. Angular error affects only the testimony of those devices, which deviation depends on phase shift between current and voltage measurement circuits in these devices - power meter, counters and phase meters.

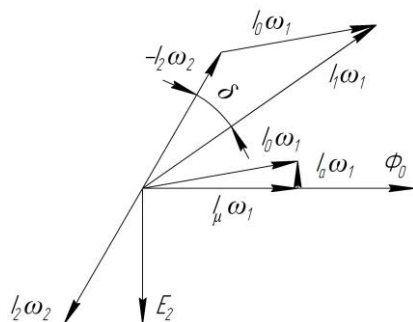

Figure 4.2 – Vector Diagram of the Current Transformer.

Based on the vector diagram of current transformer (Figure 4.2), can be folded the equation magnetomotive forces (MMF) transformer:

$$I_0\omega_1 = I_1\omega_1 + I_2\omega_2 . \quad (4.4)$$

MMF $I_2\omega_2$ creates demagnetizing effect through displacement between the vectors $I_1\omega_1$ and $I_2\omega_2$ by almost 180° . Consequently, the magnetic flux Φ_0 y creates MMF $I_0\omega_2$, which is called total transformer MMF.

In its turn, MMF $I_0\omega_1$ consists of reactive component $I_\mu\omega_1$ which creates flux Φ_0 and coincides with it by phase and active component $I_a\omega_1$, which leads flux Φ_0 by 90° and considerable hysteresis and eddy currents. At nominal operation mode of the transformer $I_0\omega_1 < 1\% I_1\omega_1$ (or $I_2\omega_2$).

At sufficient power of primary circuit, opening of secondary winding causes considerable increase of Φ_0 , because from (4.4) it follows, that $I_0\omega_1 = I_1\omega_1$. Such case refers to an extreme mode. In this case EMF of secondary winding increases to several hundred volts, which is dangerous for staff and can lead to breakdown of insulation. An increase in losses foreddy currents and hysteresis, significant heating of magnetic core and windings. Errors of current transformers are mainly determined by $I_0\omega_1$. Current I_0 depends on the quality of core material, size, number of turns, the nature and the load [8].

Load current transformers should not exceed the rated load, characterized by full rated power of secondary winding S_{2H} [VA], and are indicated on the panel.

$$\text{Rated load resistance is } Z_{2n} = \frac{S_{2n}}{I_{2n}^2} .$$

To reduce the losses of magnetic core is made of circular shape made of fine high-grade electrical steel sheet or permanganate.

Instrument voltage transformers operate in a mode close to the idle operation mode, the secondary winding is connected to voltmeter, the resistance is large [9]. Measuring voltage transformers are characterized by an angular error, which is similar to current transformers and voltage accuracy:

$$\beta_u = \frac{K_{un} - K_u}{K_u} 100\% = \frac{U'_1 - U_1}{U_1} 100\% ,$$

where $K_u = U_1/U_2$ – actual transformation coefficient, equals U_1 i U_2 ;

$K_{un}=U_{1n}/U_{2n}$ – nominal rate of transformation for the voltage;

U'_1 – measured voltage;

U_2 - voltmeter readings in the secondary winding.

The greatest influence on the error has the load in terms of the transformer secondary winding, and, unlike the current transformer, its resistance is limited to removal, that condition shall be implemented $Z_2 \geq Z_{2n}$.

Determination of errors of current transformers. Identification of errors can be one of two methods - an easier method of comparing working and exemplary transformers and differential-zero method [10].

We will use the first method, in which devices are enabled by the scheme Figure 4.3 and error determined by the formula:

$$\beta_1 = \frac{I_{2n}K_{1n1} - I_{23}K_{1n3}}{I_{23}K_{1n3}}, \quad (4.5)$$

where I_{2n} , I_{23} - ammeters evidence, turn in circles secondary transformer tested model transformer respectively;

K_{1n1} , K_{1n3} - nominal transformation ratio of the transformer, which is checked and model of the transformer, respectively.

Devices and equipment

Basic devices' list is shown in table 4.1.

Table 4.1 – List of Instruments and Equipment.

Marking in the scheme	Name of device	Type of device	Accuracy class	Technical data

The task.

Review the stand, measuring circuits and devices in the workplace. Fill in the Table 4.1 with passport data in measuring current transformers and appliances. **WARNING!** When work do not allow breaking the terminals U_1 and U_2 in the secondary windings of current transformers. This leads to dangerous voltage on the terminals. Before plugging the stand knob LATRa «PEГ.TOKA» in extreme position – counterclockwise. To make a degaussing of transformers of a current.

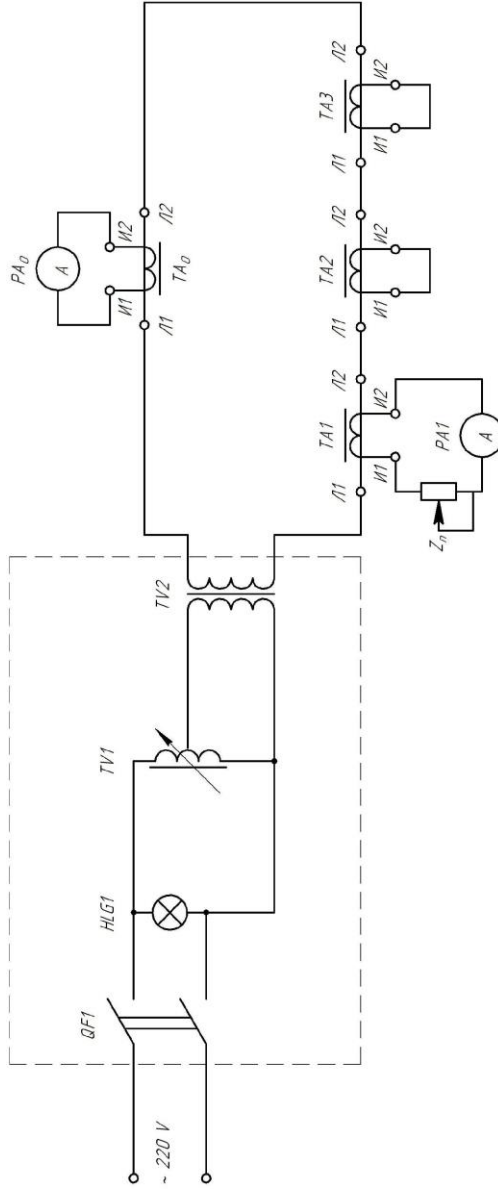

Figure 4.3 – Laboratory Test Bench Diagram.

Make calibration of current transformers. Calculate the nominal load impedance for each current transformer that is validated for his passport data. Set up Figure 4.3 scheme for calibration of transformer TA1. Other transformer secondary winding that is verified TA2 and TA3 at this time are short-circuited. Note that the range of primary current that flows through J1 and J2 clip of all current transformers are always locked and folding.

Set on the shop resistances R1 appropriate load impedance Z_n . Verification transformer should be done by digital ammeter PA1, adjusting the primary current I_1 from 0 to 5 A by LATRa TV1. Install load impedance $Z = kZ_n$, where coefficient k is given by the teacher. Repeat verification transformer. Similarly, perform verification of transformers TA2 and TA3. Results of measurement put in Table 4.2.

Table 4.2 – Results of Measurements and Calculations.

Type TA	Readings						Calculated errors					
	TK-20		TIIJIM		TΦH		TK-20		TIIJIM		TΦH	
Loaded	Z _n	KZ _n	Z _n	KZ _n	Z _n	KZ _n	Z _n	KZ _n	Z _n	KZ _n	Z _H	KZ _n
	0,2	0,4	0,4	0,8	1,0	2,0	0,2	0,4	0,4	0,8	1,0	2,0
PA1, A	PA0, A						$\beta_1, \%$					
1												
2												
3												
4												
5												

Calculate the current error β_1 . Construct graphical dependences $\beta_1 = f(I_1)$ and define the class of accuracy for all current transformers according to their maximum error.

Research idling rate of current transformers. Remove the idle operation voltage dependence in the secondary winding of investigated current transformer on current in line $U_{20} = f(I_1)$; $I_1 = \{1, 2, 3, 4, 5\}$ A and plot its graph.

For the experiment of idle operation scheme Figure 4.3 must be used, but subject to modifications: the terminals of the investigated transformer secondary winding connect voltmeter scheme Figure 4.4. Voltmeter PV1 is available from the transformer TA2 and PV2 - from TA2 and TA3.

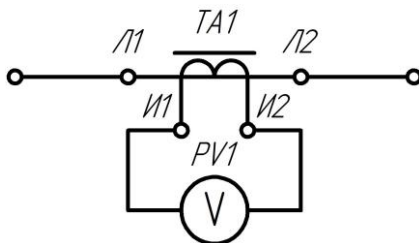

Figure 4.4 – Connection Diagram of a Voltmeter in the Secondary Circuit of a Current Transformer.

Make a conclusion on the results of experiments.

Contents of the report of the laboratory work.

The contents of the laboratory work should include the topic, the aim of laboratory work, short theoretical information, laboratory setup scheme, filled table 4.1 and 4.2, the calculations, plots of graphs $\beta_1 = f(I_1)$, $U_{20} = f(I_1)$ for each of the three transformers, conclusions of laboratory work.

Control questions.

- 1 Appointment of instrument current and voltage transformers and peculiarities of their work.
- 2 Errors of current transformers and their causes.
- 3 Vector diagram of current transformer and the equation MMF.
- 4 Rated current of secondary winding and the nominal transformer load current.
- 5 Differences between nominal and real transformation coefficients.
- 6 Means aimed at reducing errors of current transformers.
- 7 Selection of current and voltage transformers: check current transformers for emergency regimes.

List of reference sources

1. Кухарчук В.В., Кучерук В.Ю., Володарський Є.Т., Грабко В.В. Основи метрології та електричних вимірювань : підручник. Херсон : Олді-плюс, 2013. 538 с.
2. Поліщук Є.С., Дорожовець М.М., Яцук В.О. та ін. Метрологія та вимірювальна техніка : підручник. Львів : Львівська політехніка, 2012. 544 с.
3. Сусліков Л.М., Студеняк І.П. Метрологія та вимірювання : навчальний посібник. Ужгород : Видавництво УжНУ, 2014. 292 с.
4. Ціделко В.Д., Яремчук Н.А., Затока С.А., Бурченков Г.К., Шведова В.В., Стасевич В.А. Основи метрології та вимірювальної техніки : навчальний підручник / за заг. ред. Н.А. Яремчук. Київ : Видавництво «Політехніка», 2012. 266 с.
5. Шевченко О.І. Метрологія. Терміни та пояснення : довідник. Київ : ВАІТЕ, 2022. 56 с.
6. Защепкіна Н.М. (уклад.). Метрологія : навчальний посібник для студентів спеціальності 152 «Метрологія та інформаційно-вимірювальні технології». Київ : КПІ ім. Ігоря Сікорського, 2022. 397 с.
7. Закон України «Про стандартизацію». Режим доступу: <https://zakon.rada.gov.ua/laws/show/1315-18>
8. Назарова О.С., Васильєв Б.В., Шокуров Д.Р. Удосконалення системи діагностики стану холодної прокатки на основі бази даних його електромеханічних процесів. Електротехніка та електроенергетика, 2023, № 1, с. 7–18. DOI: 10.15588/1607-6761-2023-1-1.
9. Portable Colour Digital Storage Oscilloscope OWON PDS Series : user manual. Режим доступу: <http://www.saelig.com/downloads/pds5022s.pdf>
10. Nazarova O., Osadchyy V., Hutsol T., Glowacki Sz., Nurek T., Hulevskiy V., Horetska I. Mechatronic automatic control system of electropneumatic manipulator. Scientific Reports, 2024, vol. 14, p. 6970. Режим доступу: <https://doi.org/10.1038/s41598-024-56672-4>