

МІНІСТЕРСТВО ОСВІТИ ТА НАУКИ УКРАЇНИ
НАЦІОНАЛЬНИЙ УНІВЕРСИТЕТ "ЗАПОРІЗЬКА ПОЛІТЕХНІКА

Кафедра "Теоретичної та загальної електротехніки"

КОНСПЕКТ
з дисципліни "Теоретичні основи електротехніки"
для студентів спеціальності 141 "Електроенергетика,
електротехніка та електромеханіка"
усіх форм навчання
"Лінійні кола постійного струму" (англійською мовою)
Частини 1, 2, 3

LINEAR CIRCUITS OF DIRECT CURRENT

1 PHYSICAL BASES OF ELECTRICAL ENGINEERING

The science of electrical engineering is based on just a few experimentally established fundamental laws. In the interest of stressing the importance of these basic laws, attention is focused on the historical frame of reference as well as the final experimentation which culminated in their strikingly simple formulations. Once the fundamental laws are studied and understood, a considerable amount of respect will have been gained. In turn, this will facilitate the understanding of those branches of engineering where the appropriate laws provide the corresponding foundation.

We will study electrical circuits. The electrical circuit is the set of devices intended for transfer, distribution and mutual transformation electrical and other kinds of energy if the processes proceeding in devices, can be described by means of concepts about electromotive force, a current and a voltage. It consists of sources and receivers of electrical energy and the wires connecting them forming closed ways for passage of a current. We will study how each of circuit elements behaves individually and how, when they are interconnected, their interaction is governed by circuit laws.

1.1. The Three Primary Factors

There are three primary factors regarding the operation of all electrical circuits. They are voltage, current flow and resistance. These are the fundamental things that control every electrical circuit everywhere. Introducing these three factors, one can use a comparison to the flow of water to provide a comparative illustration of how electricity operates.

Voltage is the force that pushes the current through electrical circuits. It is represented in formulas with the letter U . It's measured in *volts*. The scientific definition of volts is the work necessary to force 1 ampere of current to flow through a resistance of 1 ohm.

In comparing electrical systems to water systems, voltage is comparable to water pressure. The more pressure there is, the faster the water will flow through the system. Likewise, with electricity, the higher the voltage (electrical pressure), the more current will flow through any electrical system.

Current is the rate of flow of electrical charges. The scientific description for current is the intensity of flow of the particles carrying electric charges. It is represented in formulas with the letter I . The unit of current is

ampere (A). Current compares with the rate of flow in a water system, which is typically measured in gallons per unit. In simple terms, electricity is thought to be the flow of electrons through a conductor.

Resistance is oppositional to the flow of electricity. In formulas it is represented by the symbol R . Resistance is measured in *ohms*, and ohms are represented by the Greek capital letter omega (Ω).

A more modern term for the opposition to the flow of electrical current is *impedance*. It is important to differentiate between impedance and resistance. Resistance is a fine term for direct-current circuit only. Impedance can be used for either direct- and alternating-current circuits.

1.2. Origins Inside of Atom

Electricity begins in atoms. Atoms are regarded as the smallest particles that retain the properties of element. Figure 1.1 shows the simplest atom, hydrogen. A molecule is the smallest unit quantity of matter that consists of one or more atoms and retain all the properties of the original substances.

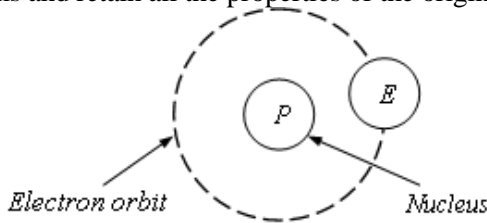

Fig. 1.1. Hydrogen atom with one proton and one electron

Atoms are composed of two main parts: a hard central core known as a nucleus, and electrons that move around the nucleus.

There are three types of particles that make up atoms: *protons* are positively charged particles; *electrons* are negatively charged particles; *neutrons* are particles that have no charge at all. The nucleus contains two types of particles: one is known as proton and carries a positive charge, the other is neutron which is electrically neutral, that is it carries no charge.

So, protons and neutrons always form the nucleus of an atom, and electrons always move around the nucleus. They carry the smallest negative charge and have a negligible mass because of their submicroscopic sizes.

The positive charge of a proton is numerically equal to the negative charge of an electron. The positive charges and the negative charges bal-

ance themselves. Normally, the atom is electrically neutral, because it consists of as many protons as electrons.

1.3. Charge and Electric Forces

Electrical charge and its movement are the most basic items of interest in electrical engineering. The basic component of charge is an electron, which carries a negative charge $1.6 \times 10^{-19} \text{ C}$, where C is the unit of charge given in coulombs. One coulomb of charge therefore represents a tremendous number of electrons. The nuclei of atoms contain an equal amount of positive charge in the heavier protons.

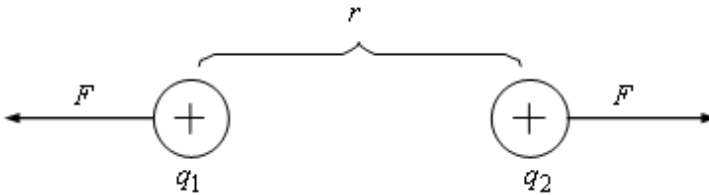

Fig. 1.2. Illustration of Coulomb's Law

Charges of the same sign tend to repel each other, and charges of opposite sign tend to be attracted together. Thus, charges exert forces on each other. It is the electric force that we are interested in utilizing and controlling. For example, consider two charges q_1 and q_2 , separated by some distance r . The force F exerted on one charge by the other varies inversely with the square of the separation between them and directly proportional to the strengths of the charges according to *Coulomb's Law* (see Fig.1.2):

$$F = k \cdot \frac{q_1 \cdot q_2}{r^2} = \frac{q_1 \cdot q_2}{4\pi \cdot \epsilon \cdot \epsilon_0 \cdot r^2}. \quad (1.1)$$

where q_1 and q_2 are the charges expressed in coulombs, r is the distance between the charges in meters, $\epsilon_0 = 8.854 \times 10^{-12} \text{ F/m}$ is the *permittivity* of free space (vacuum) and ϵ is the relative permittivity of medium. The relative permittivity is a dimensionless quantity.

1 4. Voltage

Since charges exert forces on other charges, energy must be expended in moving a charge in the vicinity of other charges. The unit of energy is the joule (J), where one joule is the energy expended in the application of

one newton of force in moving an object through a distance of one meter ($J = N \cdot m$).

For example, consider Fig. 1.3. Moving a charge q from point "a" to point "b" in the presence of some other charge Q requires a net expenditure of energy. The force of Q may oppose the movement of q over certain portions of the route, while over other portions this force may be in a direction so as to aid the movement of q . Thus, it reasonably follows that if we move the charge from point "a" to point "b" and return it to point "a", the net expenditure of energy will be zero.

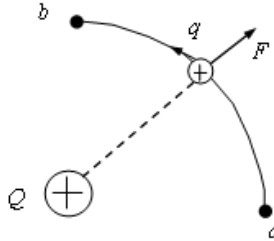

Fig. 1.3. - Voltage (potential difference) between two points in terms of the work required for moving a charge between those points.

This result is explained by the fact that charge Q has a type of force field around it which tends to repel charges of like sign and attract charges of unlike sign. If we move a charge q from point "a" to point "b" and energy W_{ab} is expended, and it is worthwhile at this point to use a description which stresses not so much the total work imparted but rather the total work per unit charge, which is called *voltage*.

So, we can say that the voltage U between these two points is the work required per unit charge:

$$U_{ab} = \frac{W_{ab}}{q}. \quad (1.2)$$

Hence, the voltage is the potential difference between two points. The unit of voltage is *volt* (V), where $1V = 1J/1C$. Knowing the direction (polarity) of this voltage, or electrical potential, is as important as knowing its magnitude, since this will determine whether energy is to be expended by us or by the force field when a charge is moved between these two points. Thus, the voltage across a branch of a circuit is the potential difference existing at the terminals of that branch. In a branch containing no

e.m.f. the current moves from a point of higher potential to one of lower potential. In this case the charge gives up energy.

Conversely, when a unit charge moves from a point of lower potential to one of higher potential it receives energy. The potential difference (p.d.) at the terminals of a resistance is also called the voltage across a resistance. It is also referred with such terms as *voltage rise* or *voltage drop*. In this text the latter term will be used. The positive direction of a voltage drop is the positive direction of the current in the resistance.

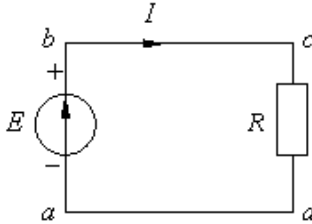

Fig. 1.4. - Example of the electric circuit.

Look at Fig. 1.4 for an illustration of the application of these terms. Current is assumed flowing in a clockwise direction, which means that either positive charges are moving clockwise or negative charges are moving counter-clockwise. As the positive charges move through the voltage rise from a to b they receive energy so that the potential of b is higher than a . However, as they move from c to d they undergo a voltage drop, thereby losing energy to the device appearing between these two points. It is interesting to note that the stream of charge gains energy in one part of the circuit (at the active element) and gives it up at the other part (the passive element). Of course, the total energy remains unchanged in accordance with the law of conservation of energy. The positive direction of voltage in diagrams is shown by an arrow.

1.5. Current and Magnetic Forces

Current is the rate of movement of electrical charge. Consider Fig. 1.5, a in which we have shown a charge moving along a cylinder.

A certain amount of positive charge Q_R^+ and negative charge Q_R^- is moving to the right across some cross section of the cylinder, and similar quantities Q_L^+ and Q_L^- are moving to the left. The net positive charge moving to the right is

$$Q = Q_R^+ - Q_R^- - Q_L^+ + Q_L^- \quad (1.3)$$

since negative charge moving to the right is equivalent to positive charge moving to the left.

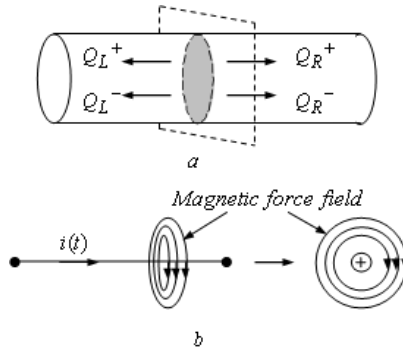

Fig. 1.5. - Electrical current a) net movement of positive charge; b) magnetic force field around a current-carrying wire

If we observe the charge crossing the area at certain time interval Δt , the current i directed to the right is the rate of movement of net positive charge to the right per unit of time:

$$i = \frac{Q}{\Delta t}. \quad (1.4)$$

The unit of current is ampere (A), where one ampere of current is the movement of one coulomb of net positive charge past the cross-sectional area of a wire per one second (s): $1A = 1C/1s$. The rate of charge movement may not be constant but may vary with time:

$$i(t) = \frac{dq}{dt}. \quad (1.5)$$

In most metallic conductors, such as wires, current is exclusively the movement of free electrons in the wire. Since electrons are negative, the charges are thus moving in a direction opposite to the direction of the current designation. The net positive charge movement is nevertheless in the direction we designate for i .

A current-carrying wire has a magnetic force field around it just as an electrical charge has an electrical force field around it. This magnetic force field appears as concentric circles around the wire; at a constant radius r from the wire, the magnetic force is the same (Fig. 1.5, b).

The electrical force field of a positive charge always points away from the charge, and vice versa for the negative charge. If we place an or-

dinary bar magnet of a compass in the vicinity of the wire, the compass needle will align with the direction of the magnetic force field.

Electric current is defined as the time rate of change of charge passing through a specified area. The moving charges may be positive or negative; the area may be the cross-sectional area of a wire or some other suitable spatial area where charges are in motion.

Expressed mathematically we can write

$$i = \frac{dq}{dt}. \quad (1.6)$$

In this equation i denotes the instantaneous electric current and q represents the net charge, which may be of the positive as well as negative kind. The amount of current is measured in amperes.

1.6. Gauss's Law

This law is an important consequence of Coulomb's Law and provides additional useful knowledge, which is needed in the work that follows in Chapter 2. In this connection consider that a sphere of radius r is put around a point charge q as depicted in Fig. 1.6.

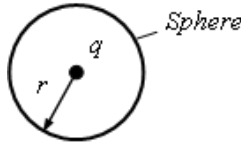

Fig. 1.6. Configuration for deriving Gauss's electric flux law

The electrical engineers have to take into account important vectors:

\vec{D} and \vec{E} . \vec{D} is called the *electric displacement* or *electric induction*. It is defined as the property of the field which is evidenced by its ability to induce charges on conductors placed in it.

The *electric field strength* (or *electric intensity*) \vec{E} is a vector quantity defined at any point in a field by magnitude and direction.

If we consider a stationary positive charge so small that it will not bring about any changes in the distribution of charges on the bodies producing the field, the ratio of the force acting on the charge to the magnitude of the charge gives the electric field strength at that point:

$$\vec{E} = \frac{\vec{F}}{q}.$$

So, the *electric field strength is numerically equal to the force acting on a unit charge*. Taking into account all above-stated, the Gauss theorem may be stated in following ways.

1. The surface integral of the normal component of the electric displacement, i.e. the total normal displacement flux, over a closed surface enclosing a certain volume is equal to the algebraic sum of the free charges within this surface:

$$\oint \vec{D} \cdot \vec{ds} = \sum q_f. \quad (1.7)$$

Rewriting this equation for our sphere yields

$$q = D A = 4\pi r^2 D. \quad (1.8)$$

The quantity D is identified as an *electric flux density* because it is combined with an area term $A = 4\pi r^2 =$ area of sphere, to yield charge, which is also called *electric flux*.

2. Since $\vec{D} = \epsilon_o \epsilon \vec{E}$, then Gauss' theorem for a homogeneous and isotropic medium can be written as

$$\oint \vec{E} \cdot \vec{dS} = \frac{\sum q_f}{\epsilon_o \epsilon},$$

that is, the surface integral of the normal component of the electric field strength, or the total normal field strength flux, over a closed surface is equal to the total free electric charge within the surface divided by the product $\epsilon_o \epsilon$.

1.7. Ohm's Law

This law is perhaps one of the first things learned about electricity in any elementary course on the subject.

By following the formulation of Fourier's heat conduction equation and using electric field intensity as analogous to temperature gradient, Ohm was able to show that the current flow in a circuit composed of a battery and conductors can be expressed as

$$I = \frac{S}{\rho} \frac{du}{dl} \quad (1.9)$$

where the derivative term denotes the electric field gradient, and $S = 4\pi r^2$ = area of sphere. In the language used by Ohm u was called the electroscopic force by way of representing the volume density of electricity at a point in the conductor - a terminology consistent with the analogous situation in heat flow through a solid described in terms of the quantity of heat per unit volume. In the case where a conductor of uniform cross-sectional area is used, Eq. (1.9) may be written as

$$I = \frac{S}{\rho} \frac{U}{l} = \frac{U}{R} \quad (1.10)$$

where U is the potential difference in volts appearing across the conductor of length l , S is the cross-section area; ρ is the property of the material called the *resistivity*; R is the resistance of the conductor in ohms. In the case of a rectangular conductor which has constant cross-section R is found as

$$R = \rho \cdot \frac{l}{S} \quad (1.11)$$

where S - the conductor cross-section, (m^2).

Ohm's law may be alternatively expressed as

$$U = IR. \quad (1.12)$$

In this form it states that for any given potential difference, the amount of current produced is inversely proportional to the resistance, which in turn is dependent upon the composition of the wire.

1.8. Instantaneous power and energy of an electric current.

The Joule-Lenz's law

When current flows through a section of a circuit an electric field fulfils work. The energy of movement (the energy of a current) will change into internal (thermal) energy of conductors, and all allocated energy dissipates in environment after some increase in their temperature. For an interval of time Δt a charge $\Delta q = I \cdot \Delta t$ proceeds through a section of a circuit. The work fulfilled by electric field in the part of a circuit:

$$\Delta A = (\varphi_a - \varphi_b) \Delta q = U \cdot I \cdot \Delta t \quad (1.13)$$

where $U = U_{ab} = \varphi_a - \varphi_b$ is the voltage across a considered section. Taking into account Ohm's law it is possible to present (1.13) expression into the following state:

$$\Delta A = R \cdot I^2 \cdot \Delta t = \frac{U^2}{R} \cdot \Delta t . \quad (1.14)$$

Joule-Lenz's law: the work ΔA of electric current I which flows through a motionless conductor with resistance R , is equal to the quantity of thermal energy which is allocated in this conductor for the interval of time Δt :

$$W_T = \Delta A = R \cdot I^2 \cdot \Delta t . \quad (1.15)$$

The power of an electric current is equal to the relation of current work ΔA to an interval of time Δt for which this work has been made:

$$P = \frac{\Delta A}{\Delta t} = U \cdot I = R \cdot I^2 = \frac{U^2}{R} . \quad (1.16)$$

The work of electric current is measured in *joules* (J), power is measured in *watts* (Wt). The energy derivative in time, i.e. the speed of energy receipt in time, represents instantaneous power of section of a circuit:

$$p = \frac{dW}{dt} = u \frac{dq}{dt} = ui . \quad (1.17)$$

Instantaneous power is an algebraic value. It is positive when current and voltage coincide in sign (when a section of the circuit has got the energy from other part of a circuit). It is negative if current is opposite to voltage (a section gives out the energy to the circuit).

1.9. Electromotive force

For making constantly existing electric field in a conductor, it is necessary a current (voltage) source be in current-carrying circuit. If a moving of charges in a source is excited by the external forces which have not been caused by an electrostatic field, the energy of external fields, exciting these forces, will be converted into electric energy. Thus, the surplus of positive charges is made up at one terminal marked out by a plus sign, and the surplus of negative charges is made up at the other terminal marked out by a minus sign. An electric field is created inside a source and in external electric circuit as a result of separation of charges.

The sources of electric energy are characterized by an *electromotive force (e.m.f.)*. The e.m.f. is equal to the operation of an external forces expended on displacement of an individual positive charge inside a source from a terminal with a lower potential to a terminal with a higher potential, and is marked out as E .

As the external forces act only in the current source between its electrodes, the e.m.f. is the source description, and it does not depend on an external network. Irrespective of the nature of external forces, the e.m.f. of a source is numerically equal to a voltage between terminals of the energy source in the absence of a current. The instantaneous value of e.m.f. is marked out $e(t)$. The electromotive force is measured in volts (V).

1.10. Basic Characteristics of a Magnetic Field

Just as in the space enclosing electric charges, there is an electric field, and in the space, enclosing moving charges and constant magnets, there is a force field which is termed as *magnetic* one.

The major singularity of a magnetic field is that it is created only by moving charges, and it acts only on moving charged particles. The parameters of a magnetic field are *magnetic induction* (or flux density) B , *magnetic intensity* (or magnetic field strength) H , and *magnetization* J .

The magnetic induction B at any point in a magnetic field is a vector quantity that determines the e.m.f. induced in an elementary conductor that is moving through the field at that point.

It numerically equals to the meaning of force F with which the magnetic field acts in the given point on individual charge q which moves with individual velocity v and has a direction, perpendicular to force and velocity vectors, coinciding with a translation of the right screw at its twirl from a force direction to a direction of velocity of a particle with a plus charge.

$$B = \frac{F}{qv} . \quad (1.18)$$

If everywhere the vector B is the same numerically and in the direction, the field is considered to be homogeneous. The unit of magnetic induction is the *tesla* (T).

The lines of the magnetic field force are the lines of a magnetic flux. In each point of these lines, the vector of the magnetic induction is directed

on a tangent to this line. Each line of a magnetic field is the line of the equal induction.

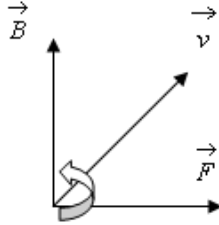

Fig. 1.7. The displacement of the vector of magnetic induction

The vector of magnetic induction \vec{B} is directed perpendicularly to the plane which it is organized by mutually perpendicular vectors of velocity \vec{v} and force \vec{F} (Fig. 1.7). The magnetic intensity H at any point in a magnetic field is defined as a force which produces, or is associated with, the magnetic induction at that point. The magnetization J at any point in a magnetic field is defined as the magnetic moment per unit volume.

The three quantities are related thus

$$B = \mu_o(H + J) \quad (1.19)$$

where μ_o is a permeability of a vacuum (free space). The magnetic intensity and the magnetization are measured in ampere per meter. The magnetization is in the same direction as magnetic intensity at that point and is directly proportional to the magnetic intensity within the material. Thus

$$J = \chi H \quad (1.20)$$

where χ is the *magnetic susceptibility* of the material and is in turn a function of H . Substituting Eq. (1.20) in Eq. (1.19) and putting $1 + \chi = \mu_r$, we get

$$B = \mu_o \mu_r H \quad (1.21)$$

where $\mu_o = 4\pi \times 10^{-7} = 1.256 \times 10^{-6} \text{ H/m}$.

The magnetic flux Φ through the area S is the surface integral of the normal component of the magnetic induction vector over that area, or

$$\Phi = \int_S B dS \quad (1.22)$$

where dS is an element of area S . Magnetic flux is measured in webers.

2 ELECTRIC CIRCUIT AND ITS ELEMENTS

2.1. The basic notions of an electric circuit

An electric circuit is an interconnection of electric devices such as energy sources, energy converters or loads, and conductors that connect the source and the loads. *Energy sources* are devices converting chemical, mechanical or other forms of energy into electric one.

For description and theoretical examination of circuit properties the notions "two-terminal network" and "four-terminal network" are introduced. A part of an electric circuit of the arbitrary configuration, observed concerning any two terminals (poles) is termed a *two-terminal network*. There are passive and active two-terminal networks. The networks which do not contain energy sources are called passive ones. The networks containing one or several energy sources are termed active ones.

The properties of transfer system are described by means of notion "four-terminal network". A *four-terminal network* is an electric circuit with two input and two output terminals. A four-terminal network usually is an intermediate link between a source of supply and a load.

A *direct current* (d.c.) is defined as a unidirectional current unvarying with time. It is flow of particles carrying electric charges (free electrons in metals, and ions in liquids). A source of electric energy is specified by the magnitude and the direction of electromotive force (e.m.f.) it generates, and its internal resistance. The unit of current I is *ampere* (A), that of the e.m.f. E , the *volt* (V), and that of resistance R , the *ohm*.

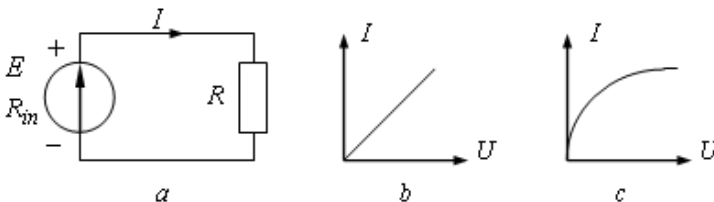

Fig. 2.1. A graphic representation of an electric circuit and volt-ampere characteristics

A graphic representation of an electric circuit is called a circuit diagram (Fig. 2.1, a). We represent resistances by rectangles, an energy

source, by a circle with an arrow inside it to indicate the positive direction of the e.m.f.

The relation between the current through a resistance and the voltage across the same resistance is called its *volt-ampere (volt-current) characteristic*. When presented graphically, voltages are laid off the abscissa, and the currents, as ordinates. There are two different types of volt-ampere (V/A) characteristics. One is a straight line; the other is a curve. Both are shown in Fig. 2.1, *b* and *c*, respectively. Resistive elements for which the volt-ampere characteristic is a straight line are called *linear*, and the electric circuits containing only linear resistances are called *linear circuits*. Resistive elements for which the volt-ampere characteristic is other than a straight line, are called *non-linear*, and so the electric circuits containing them are called *non-linear circuits*. All electric circuits actually are nonlinear. Linear they can be only in the limited ranges of current and voltage values.

The volt-ampere characteristics may be of different forms. Such volt-ampere characteristics for various resistive elements (2 - for a linear resistive element, 1 and 3 - for nonlinear resistive elements) are presented in Fig. 2.1. In an appearance from a linear resistive element each point of volt-ampere characteristic of a nonlinear element is defined by two parameters: static resistance and differential resistance.

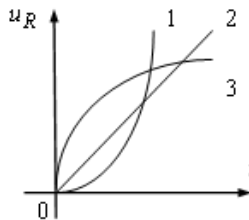

Fig. 2.2. The volt-ampere characteristics

Static or *integrated resistance* of a resistive element is numerically equal to the ratio of voltage on element terminals to the force of a current flowing through it. This resistance is proportional to a tangent of an inclination angle α of a straight line which is led from the beginning of coordinates to a working point 1 of the characteristic, in relation to an axis of currents (Fig. 2.3, *a*):

$$R_{in} = \frac{u_{1R}}{i_1} = \frac{m_u}{m_i} \cdot \operatorname{tg} \alpha = m_R \cdot \operatorname{tg} \alpha \quad (2.1)$$

where m_u , m_i , m_R - corresponding scales for a voltage, a current and a resistance.

Dynamic or differential resistance of a resistive element is numerically equal to the ratio of an infinitesimal increment of the voltage on element clips to an infinitesimal increment of a current flowing through it.

This resistance is proportional to a tangent of an inclination angle β to a tangent which is led to a working point 1 of the characteristic, in relation to an axis of currents (Fig. 2.3, b):

$$R_d = \left. \frac{du_R}{di} \right|_{i_1} = \frac{m_u}{m_i} \cdot \operatorname{tg} \beta = m_R \cdot \operatorname{tg} \beta \quad (2.2)$$

In the case if a volt-ampere characteristic is linear, the values of R_{in} and R_d don't depend on a choice of a working point and are equal to each other.

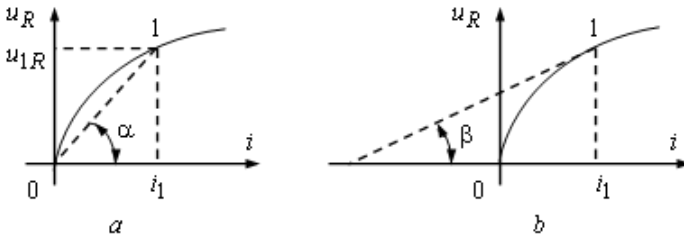

Fig. 2.3. The volt-ampere characteristics for determining the static and dynamic resistances

2.2. Ideal Voltage and Current Sources

All electric circuits are driven by sources. Independent voltage source is that the value of the voltage is not dependent on either the magnitude or direction of the current flowing through the source. Figure 2.4, a depicts the model representation of such a two-terminal source.

A voltage source, or voltage generator, connected in series with a resistance R_m (source resistance) equal to the internal resistance of the real energy source is presented in Fig. 2.4, a. The equivalent voltage generator is "idealized" in that the voltage it generates is thought of as being constant, independent of the current flowing through it, and equal to the e.m.f. of the real energy source. The internal resistance of this idealized generator is zero.

The arrow points in the positive direction of e.m.f (this is the direction in which the potential inside the generator increases).

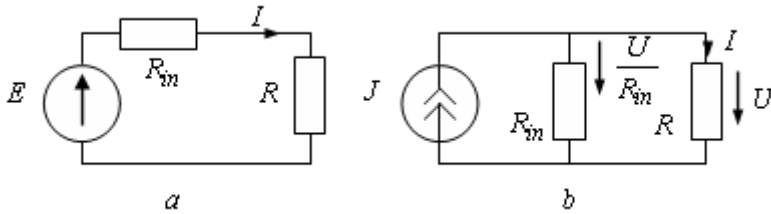

Fig. 2.4. Electric circuits

An *ideal current source* is a two-terminal element which supplies its specified current to the circuit in which it is placed independently of the value and direction of the voltage appearing across its terminals. An ideal *current source*, or *current generator*, connected in parallel with a resistance R_{in} equal to the internal resistance of the real energy source is depicted in Fig. 2.4, *b*. The equivalent current generator is "idealized" if the current J is independent of the load resistance R and equal to the quotient of the e.m.f. of the real source and its internal resistance, or $J = E/R_{in}$. In an ideal current source, its internal resistance is infinitely large.

In diagrams a current generator is symbolized by a circle with an arrow inside and letter J outside. The letter may have a subscript (say, I_k). The arrow points in the positive direction of J .

The current through the load (the resistance R) is the same in both equivalent circuits (*a* and *b* in Fig. 2.4), and equal to the current

$$I = \frac{E}{R + R_{in}}. \quad (2.3)$$

The behaviour of voltage and current generators can be presented in chart form, as in Fig. 2.5, *a* and *b*, where the current through an idealized source is related to the voltage across its terminals.

The plot of Fig. 2.5, *a* applies to a voltage generator and shows the voltage-current characteristic of an ideal voltage source. Observe that the characteristic is horizontal to the current axis, which is entirely consistent with the fact that any value of current magnitude and direction can be associated with the voltage source. Of course, it is assumed that the voltage source is not being operated beyond its energy capability, otherwise, the ideal representation is no longer valid.

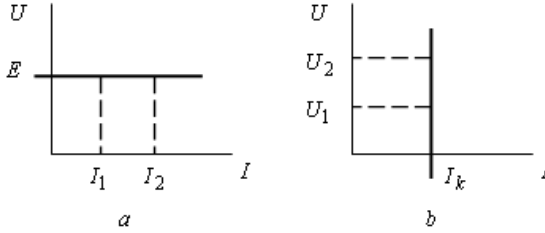

Fig. 2.5. The voltage-current characteristics

A notable point about an ideal voltage source is its zero internal resistance. This is readily demonstrated by invoking Ohm's law in incremental form as it applies to the volt-ampere characteristic. Thus we can write

$$R = \frac{\Delta U}{\Delta I} = \frac{\Delta U}{I_2 - I_1} = \frac{0}{I_2 - I_1} = 0 \quad (2.4)$$

where ΔU denotes the change in source voltage associated with a given change in current, $\Delta I = I_2 - I_1$. From Fig. 2.6 it is clear that the change in voltage associated with the change in current is zero. This result applies to all ideal voltage sources. The plot of Fig. 2.4, *b* shows the voltage-current characteristic of an ideal current source. It is easy to demonstrate that the internal resistance of an ideal current source is equal to infinite:

$$R = \frac{\Delta U}{\Delta I} = \frac{U_2 - U_1}{\Delta I} = \frac{U_2 - U_1}{0} = \infty. \quad (2.5)$$

Accordingly, when one "looks" into the terminals of a current source, one "sees" an open circuit. This is a useful bit of information to keep at hand when doing circuit analysis that involves current sources.

2.3. Real Energy Sources

In real energy sources there are losses of energy and they are replaced with two ideal elements at their calculation: - ideal electromotive force source (e.m.f. source) to which the resistive element is connected in series; - ideal current source to which the resistive element is connected. in parallel. The Resistance of an active resistive element is called an internal resistance of an energy source. The external characteristics of real sources are not parallel to axes, and cross them in the characteristic points.

They cross both axes of coordinates and these points of crossing correspond to a zero current through a source and to a zero voltage. The volt-ampere characteristic of a real source is presented in Fig. 2.6.

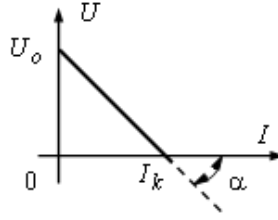

Fig. 2.6. The volt-ampere characteristic of a real source

The rate with a zero current and a nonzero voltage drop (when a load resistance is equal infinity), is called an idling mode or an open circuit, and the rate with a zero voltage drop and a nonzero current on an exit (when a load resistance is equal zero) is called a short circuit rate.

The inclination of the external characteristic is defined by internal resistance of a source which it is equal:

$$R_i = \frac{U_0}{I_k} \quad (2.6)$$

where U_0 is an idling voltage, I_k is a short circuit current.

The value of e.m.f. of an ideal source is numerically equal to the idling voltage of a real source. Accordingly, the value a current of an ideal source is numerically equal to a short circuit current of a real source. The equivalent circuit of real e.m.f. to which the load is connected, is presented in Fig. 2.7, *a*, an equivalent circuit of a real current source to which the load is connected - in Fig. 2.7, *b*.

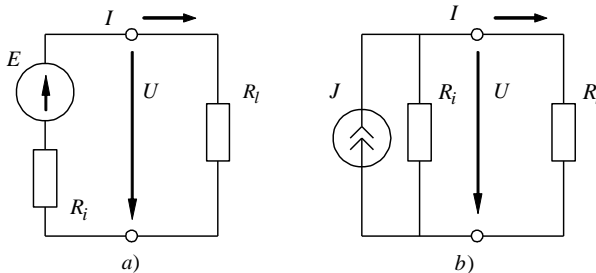

Fig. 2.7. The equivalent circuits of a real e.m.f. and a real current source

For real e.m.f. source the external characteristic is described as:

$$U = U_o - R_i I = E - R_i I . \quad (2.7)$$

And for a real current source the external characteristic is described as:

$$I = I_\kappa - \frac{U}{R_i} = J - \frac{U}{R_i} . \quad (2.8)$$

Both equivalent circuits of these real sources of electric energy (Fig. 2.7, *a* , and Fig. 2.7, *b*) are equivalent (they have the same volt-ampere characteristic) from the point of view of currents, voltages and powers in external parts of any electric circuit. Therefore, it is possible to replace any real e.m.f. source with a real current source, and on the contrary, using a parity:

$$R_i = \frac{U_o}{I_k} = \frac{E}{J} . \quad (2.9)$$

Energy sources can give out the energy to other part of circuit (to work as a generator) and to take it away from a circuit (to work as a consumer).

3 LINEAR DIRECT CURRENT CIRCUITS

3.1. Ohm's Law for a Branch

This law is perhaps one of the first things learnt about electricity in any elementary course on the subject.

A mathematical description of Ohm's law:

$$I = \frac{U}{R} \quad (3.1)$$

where I is the current in amperes flowing in the circuit, U is the potential difference in volts appearing across the conductor, R is the resistance of the conductor in ohms. So, the current in any electric circuit is equal to the voltage or electromotive force (e.m.f.) divided by the entire resistance of the circuit. Ohm's law states that the strength of the current in a wire is directly proportional to the voltage between its ends, and inversely proportional to the resistance. Accordingly, the amount of voltage is equal to the amount of current multiplied by the amount of resistance.

Ohm's law may be alternatively expressed as

$$U = I \cdot R \quad (3.2)$$

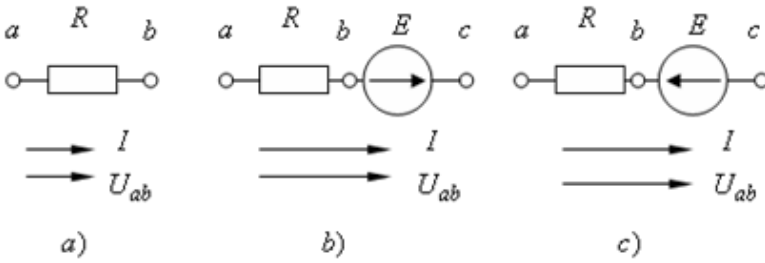

Fig. 3.1. Illustration of Ohm's law

Ohm's Law for a circuit branch with no e.m.f. in it is related its current and voltage. Thus, for Fig. 3.1, *a*

$$U_{ab} = I \cdot R \quad (3.3)$$

or

$$I = \frac{U_{ab}}{R} = \frac{\varphi_a - \varphi_b}{R} \quad (3.4)$$

Ohm's Law for a branch with a resistance and the e.m.f. gives the current in the branch in terms of the potential difference existing at its terminals and the e.m.f. it contains. Thus, for Fig. 3.1, *b* we have

$$I = \frac{\varphi_a - \varphi_b + E}{R} = \frac{U_{ac} + E}{R} \quad (3.5)$$

Similarly, when we have a circuit branch with a resistance and e.m.f. opposite to the current in it (See Fig. 3.1, *c*):

$$I = \frac{\varphi_a - \varphi_b - E}{R} = \frac{U_{ab} - E}{R} \quad (3.6)$$

In the general case

$$I = \frac{\varphi_a - \varphi_b \pm E}{R} = \frac{U_{ab} \pm E}{R} \quad (3.7)$$

Equation 3.7 is a mathematical expression of Ohm's Law for a branch containing an e.m.f. The "plus" sign before E applies to the case of Fig. 3.1, *b*, and the "minus" sign - to the case in Fig. 3.1, *c*. In a special case, when $E = 0$, Eq. 3.7 is reduced to Eq. 3.5.

3.2. Single- and Multi-Mesh Network

An electric circuit is a closed path for current flow. Electricity needs a complete loop to flow. With a broken path it will not move.

The word *network* is used synonymously with the term circuit and refers to any arrangement of passive and/or active circuit elements which form closed paths. Illustrated in Fig. 3.2 is a typical network.

Electric circuits may be divided into networks providing a single closed path known as a *mesh*, and networks providing several closed paths. A *single-mesh* network in which all the elements carry the same current is shown in Fig. 2.4, *a*. A *multi-mesh* network is shown in Fig. 3.2.

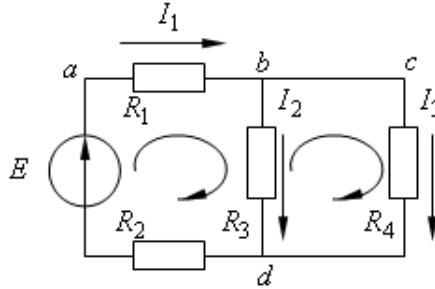

Fig. 3.2. An elementary multi-mesh network

The electric scheme shows the connection of elements in an electric circuit. A *node* of a network is an equipotential surface at which two or more circuit elements are joined. Thus in Fig. 3.2 terminals *a*, *b*, *c* and *d* are nodes. It is also called a *simple node* (the node which may be eliminated). *Junction or difficult node* is that point in a network where three or more wires are joined. In the network of Fig. 3.2 there are two junction points: *b* and *d*.

A section of the circuit between two junctions is called *electric branch*. It is formed by one or several elements which are connected by simple nodes. The same electric current flows in all elements of branch. The elements in one branch are connected *in series*. Branches which have two common nodes are connected *in parallel*. We can see three branches in this circuit (Fig 3.2).

A *mesh*, (*loop*, *contour*) is any closed path of the network. Examples of loops in the figure are *abda*, *dbcd* and *abcda*.

A mesh is the most elementary form of a loop. It cannot be divided into other loops. In the circuit both loops *abda* and *dbcd* qualify as meshes, but *abcda* cannot because it encloses the first two loops. *The closed mesh* is a set of branches forming a way, moving along which it is possible to return to a starting point, not passing more than once through each branch.

The contour containing at least one branch, not entering into other contours is called *as independent*. Depending on the way of connection of elements of an electric and circuit one must distinguish *the ramified* and *non-ramified* circuits. In *non-ramified* circuits all elements are connected in series. In *ramified circuits* elements incorporate in series, in parallel, in "delta" or in "wye" connections.

3.3. Kirchhoff's Laws

Robert Kirchhoff published the first systematic formulation of the principles governing the behaviour of electric circuits. His work was embodied in two laws - a current and voltage law - which together are known as Kirchhoff's laws. Electric circuit theory is based upon these laws.

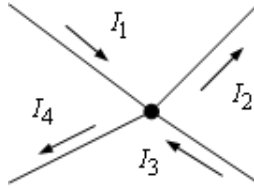

Fig. 3.3. Illustration of the Kirchhoff's current law

Kirchhoff's current law (abbreviated KCL) states that *the sum of the currents entering or leaving a junction point at any instant is equal to zero*. A junction point is that place in a circuit where two or more circuit elements are joined together. It is often called an independent node.

KCL or the first Kirchhoff's law may be also formulated in two ways: (1) *The algebraic sum of the currents flowing into a junction is zero.*

(2) *The total current entering any junction of a circuit is equal to the total current leaving that junction.* It may be expressed mathematically as

$$\sum_{k=1}^n I_k = 0 \quad (3.8)$$

where n denotes the number of circuit elements connected to the node. For the circuit of Fig. 3.3 there are four circuit branches joined at a node. Referring to Fig. 3.3 and assuming that the currents entering a junction are positive and those leaving it are negative, from the first statement it follows

$$I_1 - I_2 + I_3 - I_4 = 0. \quad (3.9)$$

The minus signs are used because these currents are defined as leaving rather than entering a node. Equation (3.9) may be rewritten as:

$$I_1 + I_3 = I_2 + I_4. \quad (3.10)$$

And it states in the mathematical terms that the current entering the node is equal to the sum of the currents leaving it.

Physically, Kirchhoff's current law implies that there can be no accumulation of electric charge at any junction of a circuit.

Kirchhoff's voltage law (abbreviated KVL) or the second Kirchhoff's law may likewise be stated in two ways:

(1) at any time instant *the algebraic sum of voltages in any closed circuit is zero*. Essentially this law is a restatement of the law of conservation of energy. A generalized formulation of KVL is written as

$$\sum_{k=1}^n U_k = 0. \quad (3.11)$$

(2) *The net voltage drop round a closed circuit equals the net e.m.f. acting in the same direction round the circuit:*

$$\sum_{k=1}^m R_k \cdot I_k = \sum_{k=1}^n E_k. \quad (3.12)$$

The terms enter the respective sum with the "plus" sign if they are in the direction of summation round the circuit, and with the "minus" sign, if they are in the opposite direction.

Kirchhoff's laws are used in circuit problems to find the branch currents. Since each branch carries a current of its own, there are as many unknown currents as there are branches.

Before writing down the Kirchhoff's equations for solution, one should: (a) draw the meshes, that is assume a positive direction for each current by placing an arrow along the respective branch; (b) assume a positive direction for summation round each mesh (loop) so that the Kirchhoff's voltage law can be written by inspection of the meshes.

For uniformity the same direction of summation round all the meshes should be chosen, for example, clockwise.

Let there be m branches and n nodes in a network. Then for the equations to be linearly independent, as many of them should be written by the Kirchhoff's current law as there are nodes minus one, or $(n - 1)$. By the

Kirchhoff's voltage law one should write as many equations as there are branches minus the number of equations written by the Kirchhoff's current law, or $m - (n - 1)$. In writing equations by the Kirchhoff's voltage law it is important to choose *independent* meshes.

Example 2. Find the branch currents in the network of Fig. 3.2, for $E = 100 \text{ V}$, $R_1 = 5 \ \Omega$, $R_2 = 15 \ \Omega$, $R_3 = 10 \ \Omega$ and $R_4 = 20 \ \Omega$.

Solution: Assume a positive direction for current flow in each branch. It is two nodes here/. So, only one equation can be written by KCL:

$$I_1 - I_2 - I_3 = 0 .$$

From Kirchhoff's voltage law there must be $n - (m - 1) = 3 - (2 - 1) = 2$ equations. Assume clockwise summation round the meshes. Thus, for the left-hand mesh (loop) in Fig. 3.2 one can write

$$(R_1 + R_2) \cdot I_1 + R_3 \cdot I_2 = E .$$

For the right-hand loop we can write

$$-R_3 \cdot I_2 + R_4 \cdot I_3 = 0 .$$

To the right of this equation we have zero because there are no e.m.f. in this loop. And the voltage drop $R_3 I_2$ has the "-" sign because I_2 flows against the direction of summation. Solving these three equations simultaneously gives $I_1 = 3.75 \text{ A}$; $I_2 = 2.5 \text{ A}$; $I_3 = 1.25 \text{ A}$. All the currents are positive, it means that we have chosen the directions of currents correctly.

3.4. Series and Parallel Combinations of Resistances

Circuit elements that carry the same current are said to be in series. Thus, *series connection* is such a connection of elements in electric circuit in which each pair of elements is joined by one simple node. Any series connection can include the arbitrary number of resistors and voltage sources. The same current flows through all the elements when they are connected in series. The circuit parameters appearing in Fig. 3.4, *a* are in series.

Applying Kirchhoff's voltage law, to the circuit of Fig. 3.4, *a* reveals a simple rule for handling resistances in series. Calling all voltage drops positive and voltage rises negative, as the circuit is traversed in the assumed current-flow direction, we can write

$$R_1 I + R_2 I + R_3 I + R_4 I = E . \quad (3.13)$$

Rearranging yields $I \cdot (R_1 + R_2 + R_3 + R_4) = E . \quad (3.14)$

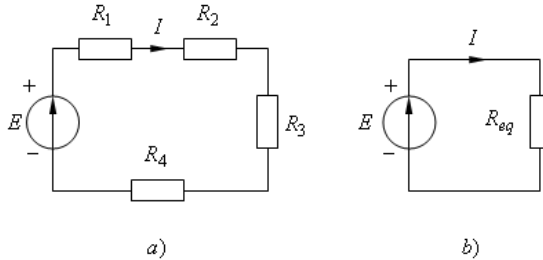

Fig. 3.4. Resistances in series: *a* original configuration: *b* equivalent circuit.

The current I is factored out because it is common to each resistance. Consequently, the quantity in parentheses may be replaced by an equivalent resistance which is given by

$$R_{eq} = R_1 + R_2 + R_3 + R_4. \quad (3.15)$$

The Eq. (3.14) may be written simply as

$$I \cdot R_{eq} = E \quad (3.16)$$

where R_{eq} denotes the *equivalent series resistance* of the circuit. It follows, too, from this analysis that the original circuit configuration of Fig 3.4, *a* may be replaced by the equivalent circuit shown in Fig. 3.4, *b*, which is merely a circuit interpretation of Eq. (3.16).

In general, if there are n series-connected resistances in a circuit, the *equivalent series resistance is obtained by taking the sum of the individual resistances*. Expressed mathematically, we have

$$R_{eq} = R_1 + R_2 + R_3 + \dots + R_n. \quad (3.17)$$

So, in series combination the equivalent resistance is equal to the sum of values of all resistances. The current can be defined by the next equation $I = U/R_{eq}$. A voltage across any resistance in this connection is defined according to Ohm's law.

Circuit elements are also very frequently found in parallel combination. In the home all electric light bulbs appear in parallel parts with respect to the source voltage. By definition circuit elements are said to be in parallel when the same potential difference appears across their terminals. So, the resistances R_1 , R_2 and R_3 in Fig. 3.5, *a* are connected in parallel.

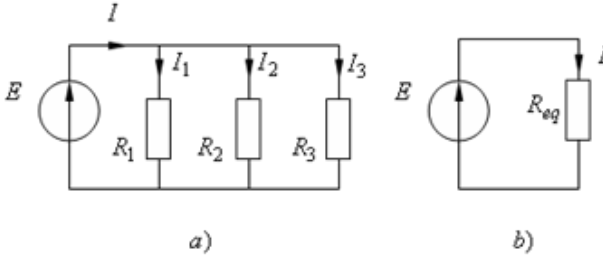

Fig. 3.5. Resistances in parallel: *a* original configuration: *b* equivalent circuit.

KCL states that the current entering some node is equal to the sum of currents leaving this node. Expressed in equation form we have

$$I = I_1 + I_2 + I_3. \quad (3.18)$$

From Ohm's law Eq (3.18) may be rewritten

$$I = \frac{E}{R_1} + \frac{E}{R_2} + \frac{E}{R_3}. \quad (3.19)$$

Again, by factoring out the common variable, which in this instance is the voltage E , there results

$$I = E \cdot \left(\frac{1}{R_1} + \frac{1}{R_2} + \frac{1}{R_3} \right). \quad (3.20)$$

The expression in parentheses may be replaced by an equivalent quantity defined as

$$\frac{1}{R_{eq}} = \frac{1}{R_1} + \frac{1}{R_2} + \frac{1}{R_3} \quad (3.21)$$

where R_{eq} denotes the equivalent resistance of the parallel combinations. Substituting Eq. (3.21) into Eq. (3.20) we obtain a simplified equation:

$$I = \frac{E}{R_{eq}}. \quad (3.22)$$

Figure 3.5. b, which is the circuit representation of Eq. 3.22, may be considered as the equivalent circuit of the configuration of Fig. 3.5, *a*.

A general formulation of the foregoing procedure states that the equivalent resistance of n parallel-connected resistances is the reciprocal of the sum of the reciprocals of the individual resistances.

Expressed in equation form this becomes

$$\frac{1}{R_{eq}} = \frac{1}{R_1} + \frac{1}{R_2} + \frac{1}{R_3} + \dots + \frac{1}{R_n}. \quad (3.23)$$

Equation (3.23) deals with the reciprocals of resistance. The unit for this quantity is siemens, *Sm*. Eq. 3.23 may also be expressed as

$$G_{eq} = G_1 + G_2 + G_3 + \dots + G_n. \quad (3.24)$$

Examples illustrating the use of Eqs. (3.15) and (3.24) to simplify circuit analysis are given in the next section. Common resistance R_{eq} when two or three resistances are connected in parallel may be expressed as

$$R_{eq} = \frac{1}{\frac{1}{R_1} + \frac{1}{R_2}} = \frac{R_1 R_2}{R_1 + R_2}, \quad (3.25)$$

$$R_{eq} = \frac{1}{\frac{1}{R_1} + \frac{1}{R_2} + \frac{1}{R_3}} = \frac{R_1 R_2 R_3}{R_1 R_2 + R_2 R_3 + R_3 R_1} \quad (3.26)$$

3.5. Series-Parallel Circuit

In many practical circuits in electric engineering there occur situations where a circuit element is in series with a parallel combination of other circuit elements. *Example 3.1.* Let consider the circuit (see Fig. 3.6) with the mixed parallel-series connection.

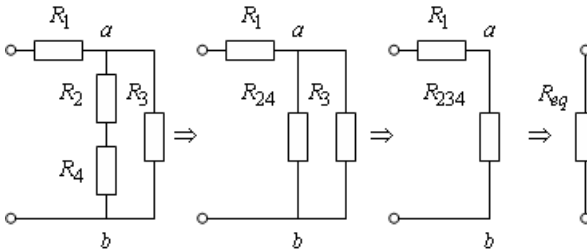

Fig. 3.6. The mixed connection

The values of resistive elements: $R_1 = 10 \Omega$, $R_2 = 15 \Omega$, $R_3 = 40 \Omega$; $R_4 = 25 \Omega$. The value of the voltage source $U = 120 V$. One should find the value of current flowing from the voltage source.

Solution: The first step - find the equivalent resistance of the series combination of R_2 and R_4 in the second branch.

Using expression (3.17), we will get:

$$R_{24} = R_2 + R_4 = 15 + 25 = 40 \Omega.$$

Now two branches form parallel connection with each other. Let's find their equivalent resistance with the help of Eq. (3.23):

$$\frac{1}{R_{234}} = \frac{1}{R_{24}} + \frac{1}{R_3} = \frac{1}{40} + \frac{1}{40} = 0,05 \text{ Sm} \quad (3.27)$$

As a result, we have got a series connection of R_1 and R_{234} . One can define the equivalent resistance of the circuit:

$$R_{eq} = R_1 + R_{234} = 10 + 20 = 30 \Omega.$$

Then one can calculate the circuit current by Ohm's law

$$I = \frac{U}{R_{eq}} = \frac{120}{30} = 4 \text{ A}. \quad (3.28)$$

3.6. Star and Delta Connection of resistive elements

The arrangement of three branches in a network as shown in Fig. 3.8a is called a *delta connection*, and the one in Fig. 3.8b as a *wye* (or *star*) *connection*. Both the star and the delta are connected to the remainder of the network at three junctions. It is often convenient to reduce a given network to a simpler arrangement by converting a star into a delta or back. Replacement of a delta of resistive elements with an equivalent star should be made so that the currents I_a , I_b , I_c and the voltages U_{ab} , U_{bc} , U_{ca} in the not affected part of the electric circuit remained the same after this conversion. For delta-to-star conversion:

$$\begin{aligned} R_a &= \frac{R_{ab} \cdot R_{ca}}{R_{ab} + R_{bc} + R_{ca}}; \\ R_b &= \frac{R_{bc} \cdot R_{ab}}{R_{ab} + R_{bc} + R_{ca}}, \\ R_c &= \frac{R_{ca} \cdot R_{bc}}{R_{ab} + R_{bc} + R_{ca}}. \end{aligned} \quad (3.29)$$

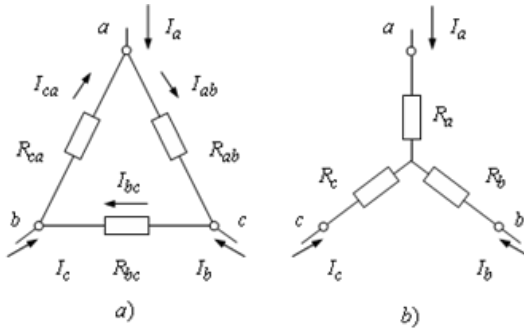

Fig.3.8. Three – terminal delta and wye networks.

Star-delta conversion is rarely used:

$$\begin{aligned}
 R_{ab} &= R_a + R_b + \frac{R_a \cdot R_b}{R_c}, \\
 R_{bc} &= R_b + R_c + \frac{R_b \cdot R_c}{R_a}, \\
 R_{ca} &= R_c + R_a + \frac{R_c \cdot R_a}{R_b}.
 \end{aligned}
 \tag{3.30}$$

3.7. The Method of Direct Application of Ohm's law (the method of curtailment)

The essence of a method of direct application of Ohm's law (it is also named the method of equivalent transformations or the method of curtailment) consists in replacement of circuit sections with equivalent resistances. It allows to reduce a complex circuit to the elementary one, i.e. consisting of an energy source and the equivalent resistance. After transformation of a circuit the calculation is reduced to a number of arithmetic operations by Ohm's law.

Example 3.2. Let consider the electric circuit in Fig. 3.9. The circuit parameters: $E = 60 \text{ V}$, $R_1 = 8 \ \Omega$, $R_2 = 56 \ \Omega$, $R_3 = 28 \ \Omega$, $R_4 = 14 \ \Omega$, $R_5 = 7 \ \Omega$, $R_6 = 6 \ \Omega$. Find currents in all circuit branches.

Solution: There are no series or parallel connections here. But we can convert delta R_2, R_3, R_4 into equivalent wye as it is shown in Fig. 3.10, a, and wye R_4, R_5, R_6 - into delta connection (see Fig. 3.10, b).

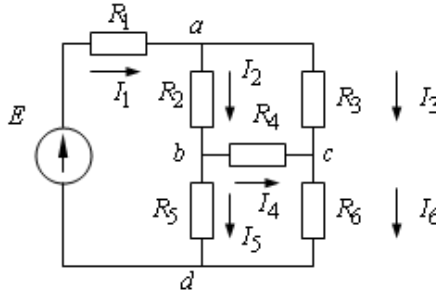

Fig. 3.9. Original circuit.

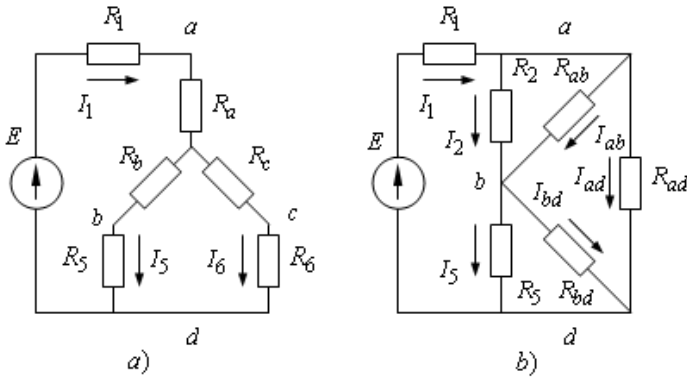

Fig.3.10

According to Eq. (3.28) the resistances of an equivalent star:

$$R_a = \frac{R_2 \cdot R_3}{R_2 + R_3 + R_4} = \frac{56 \cdot 28}{56 + 28 + 14} = 16 \, \Omega;$$

$$R_b = \frac{R_2 \cdot R_4}{R_2 + R_3 + R_4} = \frac{56 \cdot 14}{56 + 28 + 14} = 8 \, \Omega; \quad ;$$

$$R_c = \frac{R_3 \cdot R_4}{R_2 + R_3 + R_4} = \frac{28 \cdot 14}{56 + 28 + 14} = 4 \, \Omega.$$

The resistive elements R_b , R_5 and R_c , R_6 are connected consistently. Their equivalent resistance $R_{b5} = R_b + R_5 = 8 + 7 = 15 \, \Omega$;

$$R_{\bar{n}6} = R_{\bar{n}} + R_6 = 4 + 6 = 10 \, \Omega.$$

The resistors R_{b5} и R_{c6} are joined in parallel (Fig. 3.11, a).

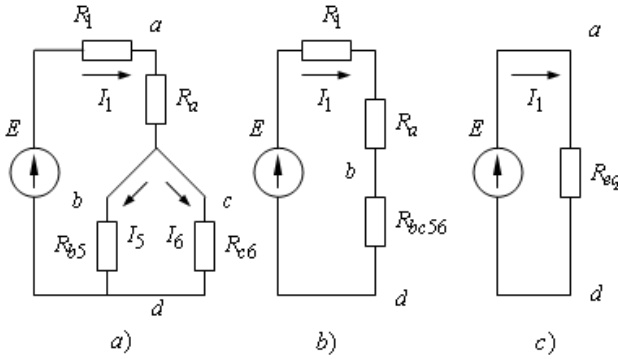

Fig. 3.11

Their equivalent resistance (by Eq. 3.25) is

$$R_{bc56} = \frac{R_{b5} \cdot R_{c6}}{R_{b5} + R_{c6}} = \frac{15 \cdot 10}{15 + 10} = 6 \Omega.$$

Now the resistors R_1 , R_a , R_{bc56} are connected in series (Fig. 3.11, b). The equivalent resistance of the circuit:

$$R_{eq} = R_1 + R_a + R_{234} = 8 + 16 + 20 = 30 \Omega.$$

The total current of the circuit (Fig. 3.11, c) by Ohm's law:

$$I_1 = \frac{E}{R_{eq}} = \frac{60}{30} = 2 \text{ A}.$$

For finding other currents we use the following method: let we have the circuit which involves two parallel resistors R_1 and R_2 .

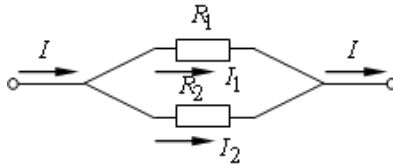

The voltage on a ramification in a case of two resistors

$$R \cdot I = R_1 \cdot I_1 = R_2 \cdot I_2 \quad (3.31)$$

where $R = \frac{R_1 \cdot R_2}{R_1 + R_2}$ is the equivalent resistance of two parallel ones.

From Eq. (3.31) we can express the current in the 1st parallel branch

$$I_1 = I \frac{R}{R_1} = I \frac{R_1 \cdot R_2}{R_1 + R_2} \cdot \frac{1}{R_1} = I \frac{R_2}{R_1 + R_2}. \quad (3.32)$$

Analogically, the current in the 2nd parallel branch

$$I_2 = I \frac{R}{R_2} = I \frac{R_1}{R_1 + R_2} \quad (3.33)$$

Equations (3.32) and (3.33) allow getting so-called "the resolving of the total current" into two parallel branches.

Then we can calculate the currents in the parallel branches using Eq. (3.32) and (3.33), (see Fig. 3.11, *a*):

$$I_5 = I_1 \frac{R_{c6}}{R_{b5} + R_{c6}} = 2 \cdot \frac{10}{15 + 10} = 0.8 \text{ A};$$

$$I_6 = I_1 \frac{R_{b5}}{R_{b5} + R_{c6}} = 2 \cdot \frac{15}{15 + 10} = 1.2 \text{ A}$$

For finding currents I_2 and I_3 we have to return to the original circuit (Fig. 3.9) and use Kirchhoff's laws. By KVL for the mesh which consists of resistors R_4 , R_5 and R_6 :

$$I_4 R_4 + I_6 R_6 - I_5 R_5 = 0, \text{ from here } I_4 = -0,114 \text{ A.}$$

The "minus" sign says that the true direction of this current does not coincide with the chosen one. Further by KCL for junctions b and c :

$$I_2 = I_4 + I_5 = -0,114 + 0,6 = 0,486 \text{ A,}$$

$$I_3 = I_6 - I_4 = 1,2 - (-0,114) = 1,314 \text{ A}$$

which are the desired results.

3.8. The Method of Direct Application of Kirchhoff's Laws

The essence of this method consists in drawing up and the following calculation of the system of independent equations by Kirchhoff's laws. The quantity of such equations must coincide with the quantity of unknown values. Usually, the unknown values are branch currents.

We define the quantity of junctions K for an initial circuit, the number of all branches N , and the number of the branches containing current sources N_J . The currents in the branches with current sources are known, so, the total quantity of equations is equal to the number of unknown branch currents.

Example 3.3. Let's consider the direct current circuit (Fig. 3.12) with parameters $E_1 = 50 \text{ V}$, $E_2 = 30 \text{ V}$, $J = 1 \text{ A}$, $R_1 = 10 \Omega$, $R_2 = 15 \Omega$, $R_3 = 20 \Omega$, $R_4 = 25 \Omega$, $R_5 = 30 \Omega$, $R_6 = 35 \Omega$. Define branch currents.

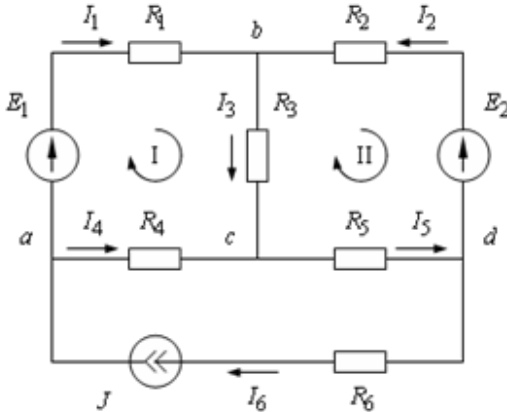

Fig. 3.12

The solution. The number of junctions is 4, so one can write down 3 equations by KCL and the missing two equations – by KVL. Writing the equations, we consider, that $I_6 = J$. We arbitrarily set the directions of branch currents. Then we can write the equations for junctions a , b and c .

$$\begin{cases} J - I_1 - I_4 = 0; \\ I_1 + I_2 - I_3 = 0; \\ I_3 + I_4 - I_5 = 0; \\ I_1 R_1 + I_3 R_3 - I_4 R_4 = E_1; \\ -I_2 R_2 - I_3 R_3 - I_5 R_5 = -E_2. \end{cases}$$

For calculation this system it is necessary to present it in matrix form:

$$AX = B,$$

where A is a square matrix of coefficients at unknown values; X is a matrix-column of unknown values; B is a matrix-column of constant terms of the equations. The solution of this system in the matrix form we search in the form $X = A^{-1}B$. As a result of calculation of this system of equations we define branch currents.

$$\begin{vmatrix} -1 & 0 & 0 & -1 & 0 \\ 1 & 1 & -1 & 0 & 0 \\ 0 & 0 & 1 & 1 & -1 \\ R_1 & 0 & R_3 & -R_4 & 0 \\ 0 & -R_2 & -R_3 & 0 & -R_5 \end{vmatrix} \cdot \begin{vmatrix} I_1 \\ I_2 \\ I_3 \\ I_4 \\ I_5 \end{vmatrix} = \begin{vmatrix} -J \\ 0 \\ 0 \\ E_1 \\ -E_2 \end{vmatrix}$$

or given data

$$\begin{vmatrix} -1 & 0 & 0 & -1 & 0 \\ 1 & 1 & -1 & 0 & 0 \\ 0 & 0 & 1 & 1 & -1 \\ 10 & 0 & 20 & -25 & 0 \\ 0 & -15 & -20 & 0 & -30 \end{vmatrix} \cdot \begin{vmatrix} I_1 \\ I_2 \\ I_3 \\ I_4 \\ I_5 \end{vmatrix} = \begin{vmatrix} -1 \\ 0 \\ 0 \\ 50 \\ -30 \end{vmatrix}$$

The currents in the branches of this electric circuit:

$$X = \begin{vmatrix} I_1 \\ I_2 \\ I_3 \\ I_4 \\ I_5 \end{vmatrix} = \begin{vmatrix} 1,535 \\ -0,472 \\ 1,063 \\ -0,535 \\ 0,528 \end{vmatrix}$$

Some currents have negative values, this means that their true directions are opposite to the chosen ones.

3.9. Network Analysis by Mesh Currents

Mesh current is one which flows around the perimeter of a mesh. Equations are written for mesh currents by KVL. On solving them the branch currents are found in terms of mesh currents. For external branches the value of real current is equal to the corresponding mesh current (taking into account their directions). For adjacent branches, the value of current is equal to an algebraic sum of corresponding mesh currents.

For a compound circuit (for example, with three meshes) the simultaneous equations according to the mesh-current method can be written as

$$\begin{cases} R_{11} \cdot I_{11} + R_{12} \cdot I_{22} + R_{13} \cdot I_{33} = E_{11} \\ R_{21} \cdot I_{11} + R_{22} \cdot I_{22} + R_{23} \cdot I_{33} = E_{22} \\ R_{31} \cdot I_{11} + R_{32} \cdot I_{22} + R_{33} \cdot I_{33} = E_{33} \end{cases} \quad (3.34)$$

where in the first of equations (3.34) current I_{11} of the first mesh is multiplied by the self-resistance R_{11} of the same mesh, and current I_{22} - by the resistance of the common (adjacent) branch, R_{12} , (or the mutual resistance) with a minus sign. This mutual resistance has the "-" sign if two mesh currents in the common branch flow against each other, and the "+" sign if they flow in the same direction.

E_{11} is the e.m.f. across the first mesh; when there are several e.m.f.s. in the loop it is equal to the algebraic sum of e.m.f.s. around that mesh. The e.m.f.s. which is in the direction of summation enter it with the plus sign. E_{22} is the e.m.f. across the second mesh; E_{33} is the e.m.f. across the third mesh; R_{22} is the self-resistance of the second mesh; R_{33} is the self-resistance of the third mesh; R_{13} , R_{23} , R_{31} , R_{32} are the resistances of the common branches (or the mutual resistances). A mutual resistance may be with the "minus" or the "plus" sign. Illustrated in Fig. 3.13 is a typical network.

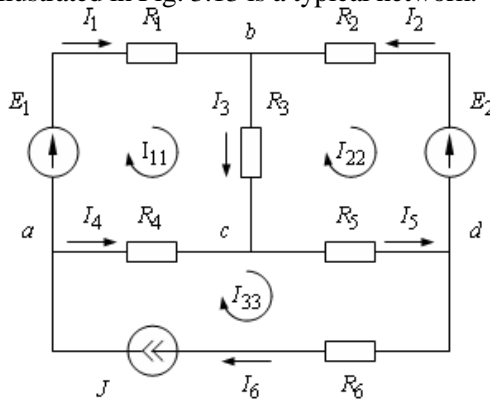

Fig.3.13

Example 3.4. Let's define currents in the circuit with parameters: $R_1 = 10 \Omega$, $R_2 = 15 \Omega$, $R_3 = 20 \Omega$, $R_4 = 25 \Omega$, $R_5 = 30 \Omega$, $R_6 = 35 \Omega$, $E_1 = 50 \text{ V}$, $E_2 = 30 \text{ V}$, $J = 1 \text{ A}$. Determine branch currents.

The solution. The directions of mesh currents I_{11} , I_{22} , I_{33} are chosen arbitrary (for example, clockwise). The current in the sixth branch is spotted by the current source. On the other side, the sixth branch is a part only of the third contour, and the chosen direction of the current in the branch coincides with the chosen direction of the mesh current. That is why $I_6 = J$. Hence, $I_{33} = J$.

Let write down equations according the Kirchhoff's voltage law for the first and second contours. The left part of the equations contains voltage drops across resistive elements of a contour created by proceeding currents, the right part – the e.m.f.s acting in the contour.

The value of e.m.f. source is considered with "+" sign if its direction coincides with the the direction of summation round the mesh. A voltage drop which is created by a natural mesh current, is always considered with "+" sign, and voltage drops created in elements by the currents of adjacent contours, are considered with "+" signs if two mesh currents in the adjacent branches coincide in direction. Equations for two meshes by KVL:

$$\begin{aligned}(R_1 + R_3 + R_4)I_{11} - R_3I_{22} &= E_1 + JR_4; \\ -R_3I_{11} + (R_2 + R_3 + R_5)I_{22} &= -E_2 + JR_5,\end{aligned}$$

where $E_{11} = E_1 + R_4J = 50 + 25 \cdot 1 = 75 \text{ V}$ is the e.m.f. across the 1st mesh; $E_{22} = -E_2 + R_5J = -30 + 30 \cdot 1 = 0 \text{ V}$ is the e.m.f. across the 2nd mesh; $R_{11} = R_1 + R_3 + R_4 = 10 + 20 + 25 = 55 \text{ } \Omega$ is the self-resistance of the 1st mesh; $R_{11} = R_2 + R_3 + R_5 = 15 + 20 + 30 = 65 \text{ } \Omega$ is the self-resistance of the 2nd mesh; $R_{12} = R_{21} = -R_3 = 20 \text{ } \Omega$ are mutual resistances of the 1st and the 2nd meshes.

After substituting known values, we have got:

$$\begin{cases} 55I_{11} - 20I_{22} = 85; \\ -20I_{11} + 65I_{22} = 0. \end{cases}$$

We express current I_{11} from the second equation of the system $I_{11} = 3,25I_{22}$ and substitute it in the first equation.

$$55 \cdot 3,25I_{22} - 20I_{22} = 85 \text{ or } 78,75I_{22} - 20I_{22} = 85 .$$

Then the value of the 2nd mesh current $I_{22} = 0,472 \text{ A}$. And the value of the 1st mesh current $I_{11} = 1,535 \text{ A}$. Actual currents in branches:

$$\begin{aligned}I_{11} &= I_{11} = 1,535 \text{ A}, \quad I_2 = -I_{22} = -0,472 \text{ A}, \\ I_3 &= I_{11} - I_{22} = 1,535 - 0,472 = 1,063 \text{ A}, \\ I_4 &= I_{33} - I_{11} = J - I_{11} = 1 - 1,535 = -0,535 \text{ A}, ; \\ I_5 &= I_{33} - I_{22} = J - I_{22} = 1 - 0,472 = 0,528 \text{ A}, \\ I_6 &= I_{33} = J = 1 \text{ A}.\end{aligned}$$

3.10. Node-analysis Method

The current in any branch can be found by Ohm's law for a branch containing e.m.f. But one must know the potential difference across the terminals of a branch or across the nodes bounding the branch in question. The analysis of network in which the unknown quantities are the voltages across the branches of the network is known as the node-analysis method.

When making the equations by node-analysis method one must choose a basis node to be earthed. Then we consider that its potential is equal to zero. As a result, the number of unknown potentials becomes equal to the number of the independent equations by the 1st Kirchhoff's law. On solving the system concerning these potentials, it is possible to define currents through known potentials. This method is expedient to use for calculation of the complicated electric circuits with small number of nodes.

The system of equations for any compound circuit:

$$\begin{cases} +G_{11}\varphi_1 - G_{12}\varphi_2 - \dots - G_{1m}\varphi_m - \dots - G_{1n}\varphi_n = J_{11}; \\ \dots \quad \dots \quad \dots \quad \dots \quad \dots \\ -G_{m1}\varphi_1 - G_{m2}\varphi_2 - \dots + G_{mm}\varphi_m - \dots - G_{mn}\varphi_n = J_{mm}; \\ \dots \quad \dots \quad \dots \quad \dots \quad \dots \\ -G_{n1}\varphi_1 - G_{n2}\varphi_2 - \dots - G_{nm}\varphi_m - \dots + G_{nn}\varphi_n = J_{nn}, \end{cases}$$

where $\varphi_1, \varphi_2, \dots, \varphi_n$ are unknown nodal potentials; m is a variable number of a node; $G_{11}, G_{22}, \dots, G_{nn}$ are self-conductances of nodes (the total conductance of branches which are joined to the appropriate node); $G_{km} = G_{mk}$ are mutual conductances of nodes (the total conductance of branches which join nodes k and m); $J_{11}, J_{22}, \dots, J_{nn}$ are the nodal currents considering the presence of energy sources in branches which are

joined to the appropriate node, $J_{kk} = \sum_{m=1}^n E_m G_m + \sum_{m=1}^n J_m$ is the nodal cur-

rent of node k , where $\sum_{m=1}^n E_m G_m$ is the algebraic sum of multiplications of

the branch e.m.f.s, joined to the node k , by the conductance of this branch. For all this, those ones which direct towards node enter the sum with a plus sign, and those which have the opposite directions enter the sum with a mi-

nus sum. $\sum_{m=1}^n J_m$ is an algebraic sum of the currents of current sources in

branches which are joined to the node k .

Solving the system, we define nodal potentials $\varphi_1, \varphi_2, \dots, \varphi_n$, and then the actual currents in branches.

Example 3.5. Given *dc* circuit (Fig. 3.14). with parameters $R_1 = 10 \Omega, R_2 = 15 \Omega, R_3 = 20 \Omega, R_4 = 25 \Omega, R_5 = 30 \Omega, R_6 = 35 \Omega, E_1 = 50 \text{ V}, E_2 = 30 \text{ V}, J = 1 \text{ A}$ Calculate currents in all branches.

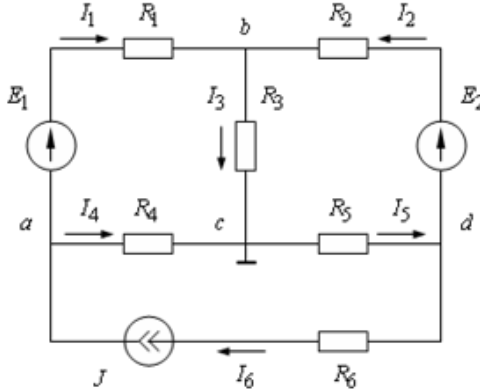

Fig.3.14

Solution. Let's express currents in branches by Ohm's law

$$I_1 = \frac{\varphi_a - \varphi_b + E_1}{R_1} = G_1(\varphi_a - \varphi_b + E_1),$$

$$I_2 = \frac{\varphi_d - \varphi_b + E_2}{R_2} = G_2(\varphi_d - \varphi_b + E_2),$$

$$I_3 = \frac{\varphi_b - \varphi_c}{R_3} = G_3(\varphi_b - \varphi_c),$$

$$I_4 = \frac{\varphi_a - \varphi_c}{R_4} = G_4(\varphi_a - \varphi_c),$$

$$I_5 = \frac{\varphi_c - \varphi_d}{R_5} = G_5(\varphi_c - \varphi_d)$$

where $G_m = 1/R_m$ is the conductance of the appropriate branch. The current in the sixth branch is defined by the current source $I_6 = J$.

The potential of node c is earthed (at zero potential). So, we have to determine only three potentials of junctions a, b, d by KCL:

$$-I_1 - I_4 + I_6 = 0,$$

$$I_1 + I_2 - I_3 = 0,$$

$$-I_2 + I_5 - I_6 = 0$$

or taking into account written before the relationships for currents:

$$-G_1(\varphi_a - \varphi_b + E_1) - G_4(\varphi_a - \varphi_c) + J = 0;$$

$$+G_1(\varphi_a - \varphi_b + E_1) + G_2(\varphi_d - \varphi_b + E_2) - G_3(\varphi_b - \varphi_c) = 0;$$

$$-G_2(\varphi_d - \varphi_b + E_2) + G_5(\varphi_c - \varphi_d) - J = 0.$$

Let's regroup the elements of the equations concerning unknown nodal potentials and we will consider, that $\varphi_c = 0$

$$\begin{cases} (G_1 + G_4) \cdot \varphi_a - G_1 \cdot \varphi_b - 0 \cdot \varphi_d = J - G_1 \cdot E_1; \\ -G_1 \cdot \varphi_a + (G_1 + G_2 + G_3) \cdot \varphi_b - G_2 \cdot \varphi_d = G_1 \cdot E_1 + G_2 \cdot E_2; \text{ or} \\ -0 \cdot \varphi_a - G_2 \cdot \varphi_b + (G_2 + G_5) \cdot \varphi_d = -J - G_2 \cdot E_2, \end{cases}$$

$$\begin{cases} +G_{11} \cdot \varphi_a - G_{12} \cdot \varphi_b - G_{13} \cdot \varphi_d = J_{11}; \\ -G_{21} \cdot \varphi_a + G_{22} \cdot \varphi_b - G_{23} \cdot \varphi_d = J_{22}; \\ -G_{31} \cdot \varphi_a - G_{32} \cdot \varphi_b + G_{33} \cdot \varphi_d = J_{33}, \end{cases}$$

where the self-conductance of node a is

$$G_{11} = 1/R_1 + 1/R_4 = 1/10 + 1/25 = 0,14 \text{ Sm},$$

the self-conductance of node b is

$$G_{22} = 1/R_1 + 1/R_2 + 1/R_3 = 1/10 + 1/15 + 1/20 \approx 0,2167 \text{ Sm},$$

the self-conductance of node c

$$G_{33} = 1/R_2 + 1/R_5 = 1/15 + 1/30 = 0,1 \text{ Sm},$$

the mutual conductance of nodes a and b

$$G_{12} = G_{21} = 1/R_1 = 1/10 = 0,1 \text{ Sm},$$

the mutual conductance of nodes a and c

$$G_{13} = G_{31} = 0 \text{ Sm},$$

(because the resistance of a branch containing a current source is infinitely large); the mutual conductance of nodes b and c

$$G_{23} = G_{32} = 1/R_2 = 1/15 = 0,0667 \text{ Sm},$$

the nodal current of the node a

$$J_{11} = J - E_1 / R_1 = 1 - 50/10 = -4 \text{ A},$$

the nodal current of the node b

$$J_{22} = E_1 / R_1 + E_2 / R_2 = 50/10 + 30/15 = 7 \text{ A},$$

the nodal current of the node c

$$J_{33} = -J - E_2 / R_2 = -1 - 30/15 = -3 \text{ A}.$$

Substitute known values into the last system of equations:

$$\begin{cases} 0,14 \cdot \varphi_a - 0,1 \cdot \varphi_b - 0 \cdot \varphi_d = -4; \\ -0,1 \cdot \varphi_a + 0,2167 \cdot \varphi_b - 0,0667 \cdot \varphi_d = 7; \\ -0 \cdot \varphi_a - 0,0667 \cdot \varphi_b + 0,1 \cdot \varphi_d = -3. \end{cases}$$

We solve this system by Cramer's rule. The results of nodal potentials:

$$\varphi_a = -\frac{0,01889}{0,001411} = -13,39 \text{ V};$$

$$\varphi_b = \frac{0,02999}{0,001411} = 21,25 \text{ V};$$

$$\varphi_d = -\frac{0,02233}{0,001411} = -15,82 \text{ V}.$$

And the currents in all branches of the electric circuit:

$$I_1 = \frac{-13,39 - 21,25 + 50}{10} = 1,536 \text{ A}, \quad I_2 = \frac{-15,82 - 21,25 + 30}{15} = 0,471 \text{ A}$$

$$I_3 = \frac{21,25 - 0}{20} = 1,063 \text{ A}, \quad I_4 = \frac{-13,39 - 0}{25} = 0,536 \text{ A},$$

$$I_5 = \frac{0 + 15,82}{30} = 0,527 \text{ A}, \quad I_6 = J = 1 \text{ A}.$$

3.11. Nodal Pairs or the Method of Two nodes

Sometimes an electric circuit may have only two nodes, as shown in Fig. 3.15. The currents in such a network can be conveniently found by the nodal-pair method. In this method we at first define the voltage between two nodes (junctions), and the branch currents are found in its terms.

Let's consider junction b to be earthed ($\varphi_b = 0$). Then proceeding from the method of nodal potentials:

$$U_{ab} = \frac{\sum_{k=1}^n E_k G_k + \sum_{k=1}^n J_k}{\sum_{k=1}^n G_k} \quad (3.35)$$

where U_{ab} is the voltage between two nodes; $\sum_{k=1}^n E_k G_k$ is the algebraic sum of multiplications of the branch e.m.f.s joined to the node, by the conductances of these branches; $\sum_{k=1}^n J_k$ is the algebraic sum of the values of current sources in the branches which are joined to the node; $\sum_{k=1}^n G_k$ is the sum of branch conductances of the electric circuit.

After definition of voltage U_{ab} a current in any branch k is defined according to Ohm's law for a circuit section:

$$I_k = G_k (\pm E_k - U_{ab}) \quad (3.36)$$

where the e.m.f.s which direct towards node a , are considered with a plus sign, and those which direct from the node a - with a minus sign.

Example 3.6. The parameters of *dc* circuit (Fig. 3.15) $E_1 = 55 \text{ V}$, $E_2 = 45 \text{ V}$, $J = 1 \text{ A}$, $R_1 = 10 \text{ } \Omega$, $R_2 = 20 \text{ } \Omega$, $R_3 = 30 \text{ } \Omega$, , $R_4 = 35 \text{ } \Omega$, $R_5 = 15 \text{ } \Omega$. One must define currents in all branches.

Solution: The conductances of branches:

$$G_1 = \frac{1}{R_1} = \frac{1}{10} = 0,1 \text{ Sm}; \quad G_2 = \frac{1}{R_2} = \frac{1}{20} = 0,05 \text{ Sm};$$

$$G_4 = \frac{1}{R_4 + R_5} = \frac{1}{35 + 15} = 0,02 \text{ Sm}.$$

The voltage U_{ab} between two nodes:

$$U_{ab} = \frac{E_1 G_1 - E_2 G_2 + J}{G_1 + G_2 + G_4} = \frac{55 \cdot 0,1 - 45 \cdot 0,05 + 1}{0,1 + 0,05 + 0,02} = 25 \text{ V}$$

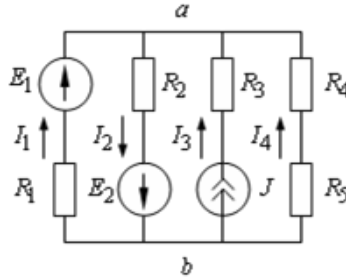

Fig. 3.15

The voltage U_{ab} between two nodes:

$$U_{ab} = \frac{E_1 G_1 - E_2 G_2 + J}{G_1 + G_2 + G_4} = \frac{55 \cdot 0,1 - 45 \cdot 0,05 + 1}{0,1 + 0,05 + 0,02} = 25 \text{ V}$$

Now we can find from Eq. (3.36) the currents in branches:

$$I_1 = G_1(E_1 - U_{ab}) = 0,1 \cdot (55 - 25) = 3 \text{ A};$$

$$I_2 = G_2(E_2 + U_{ab}) = 0,05 \cdot (45 + 25) = 3,5 \text{ A};$$

$$I_3 = J = 1 \text{ A}; \quad I_4 = -G_4 U_{ab} = -0,02 \cdot 25 = -0,5 \text{ A}.$$

3.12. Active and passive two-pole unit

The two-pole unit (or network) is a circuit of any complexity or its part which has two terminals. The two-terminal network is conditionally represented by a rectangle in figures. A two-terminal network containing a voltage or a current source, or both, is called *active* (marked by letter *A* in Fig. 3.18, *a*). A two-terminal network containing neither a voltage nor a current source, is termed *passive* (marked by letter *P* in Fig. 3.18, *b*).

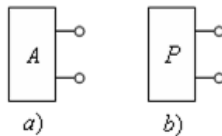

Fig. 3.16

Active two-pole unit is characterized by three parameters: open circuit (idling) voltage $U_{o.c.}$, short circuit current I_k and input resistance R_{in} .

$$R_{in} = \frac{U_{o.c.}}{I_k} \quad (3.36)$$

It is possible to replace an active two-pole unit either an equivalent real e.m.f. source, the e.m.f. of which is equal to the idling voltage between two terminals, and its internal resistance is equal to the input resistance of a two-terminal network, or the real current source the current of which is equal to a short circuit current of a two-pole unit, and its internal resistance is equal to the input resistance of a two-terminal network too. The input resistance is defined when all energy sources are removed (branches with ideal current sources are broken off, and ideal voltage sources are replaced with short-circuited crosspieces).

3.13. Thevenin's Theorem

Situations sometimes occur in electric engineering in which it is desirable to find a particular branch current in a network as the resistance of that branch is varied while all other resistances remain constant. Then we remove this branch, and the remaining two-terminal network (Fig. 3.19, *a*) can be replaced by an equivalent voltage generator (Fig. 3.19, *b*) whose e.m.f. is equal to the one appearing across two terminals when the branch is open circuited, that is there is no load in it, and whose internal resistance is equal to the resistance of two-terminal network between the branch terminals.

This method is known as *Thevenin's Theorem* or *equivalent-generator method*. The remaining two-terminal network can be also replaced by an equivalent current source (Fig. 3.19, *c*).

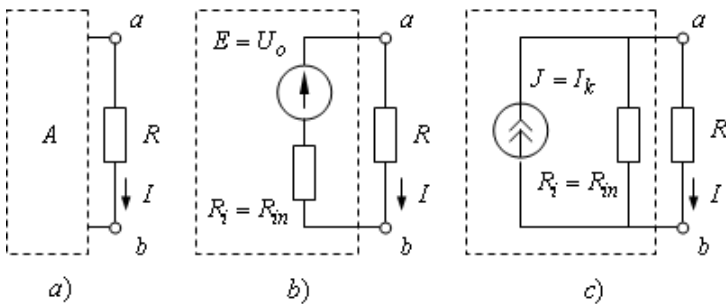

Fig. 3.17

The equivalent-generator method. For finding a current in any branch *ab* which resistance is *R*, it is necessary:

- break a branch *ab* and consider the rest part of the electric circuit as a two-terminal network;

- define the voltage between terminals ab of two-terminal network (open-circuit voltage $U_{o.c.}$);
- find input resistance R_{in} of the two-terminal network concerning terminals ab (in spite of this voltage sources are replaced by short-circuited connectors, and branches with current sources are broken);
- exchange the two-terminal network by the equivalent real e.m.f. source, whose e.m.f. is equal to the open-circuit voltage of two-terminal network $E = U_{o.c.}$, and its internal resistance is equal to the input resistance of two-terminal network $R_i = R_{in}$;
- calculate the current in the branch ab by Ohm's law:

$$I = \frac{U_{o.c.}}{R_{in} + R} = \frac{E}{R_i + R} \quad (3.37)$$

Example 3.8. Consider dc electric circuit (Fig. 3.18 *a*) with parameters $R_1 = 10 \Omega$, $R_2 = 20 \Omega$, $R_3 = 30 \Omega$, $R_4 = 35 \Omega$, $R_5 = 15 \Omega$, $E_1 = 55 V$, $E_2 = 45 V$, $J = 1 A$. Define current in the branch with the resistor R_2 .

Solution: Let's convert the initial circuit removed the branch with R_2 how it is shown in Fig. 3.18, *b*. We find the voltage between points a and b in an idling mode (Fig. 3.21, *a*).

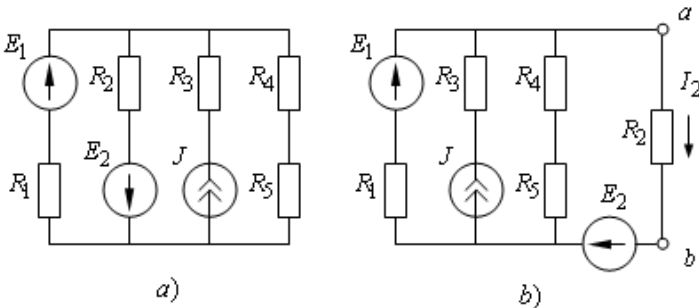

Fig. 3.18

For this purpose, we use a mesh-current method. We will consider, that in the second contour the mesh current is defined by a current source $I_{22} = J = 1 A$.

$$(R_1 + R_4 + R_5)I_{11} + (R_4 + R_5)I_{22} = E_1.$$

$$I_{11} = \frac{E_1 - J(R_4 + R_5)}{R_1 + R_4 + R_5} = \frac{55 - 1(35 + 15)}{10 + 35 + 15} = 0,0833 \text{ A};$$

$$I_{4o} = I_{11} + I_{22} = I_{11} + J = 0,0833 + 1 = 1,0833 \text{ A}.$$

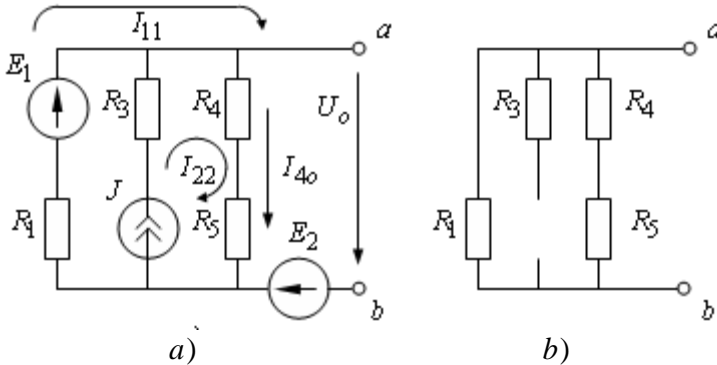

Fig. 3.19

Then we can find the open-circuit voltage appearing across the terminals of the removed branch:

$$U_{o.c.} = E_2 + (R_4 + R_5)I_{4o} = 45 + (35 + 15) \cdot 1,0833 = 99,17 \text{ V}.$$

We determine the resistance that the two-terminal network presents to the terminals a and b of the removed branch, with the voltage sources E_1 and E_2 short-circuited and all current sources open-circuited J (Fig.3.21, b):

$$R_{in} = \frac{R_1(R_4 + R_5)}{R_1 + R_4 + R_5} = \frac{10 \cdot (35 + 15)}{10 + 35 + 15} = 8,333 \text{ } \Omega.$$

Find the current in the removed branch by the equation:

$$I_2 = \frac{U_o}{R_{in} + R_2} = \frac{99,17}{8,333 + 20} = 3,5 \text{ A}.$$

We solve a problem by equivalent current source method.

We define the short circuit current using a mesh-current method (Fig. 3.22).

We will consider, that in the third contour the mesh current is defined by the known value of the current source $I_{33k} = J = 1 \text{ A}$.

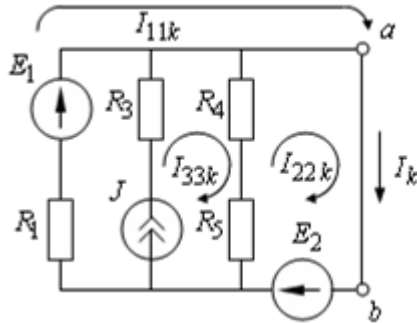

Fig. 3.20

The system of equations by the mesh-current method:

$$\begin{cases} R_1 I_{11k} = E_1 + E_2 \\ (R_4 + R_5) I_{22k} - (R_4 + R_5) I_{33k} = E_2 \end{cases}$$

The mesh currents from this system:

$$I_{11k} = \frac{E_1 + E_2}{R_1} = \frac{55 + 45}{10} = 10 \text{ A};$$

$$I_{22k} = \frac{E_2 + (R_4 + R_5)J}{R_4 + R_5} = \frac{45 + (45 + 15) \cdot 1}{45 + 15} = 1,9 \text{ A}.$$

Then the short circuit current:

$$I_k = I_{11k} + I_{22k} = 10 + 1,9 = 11,9 \text{ A}.$$

The resistance that the two-terminal network presents to the terminals a and b of the removed branch is determined in the same way as in the previous case.

The current in the removed branch:

$$I_2 = I_k \frac{R_{in}}{R_{in} + R_2} = 11,9 \cdot \frac{8,333}{8,333 + 20} = 3,5 \text{ A}.$$

As we can see the current value I_2 found by two methods coincides with its value which was got as a result of the decision of this problem in the Example 3.6.

3.14. The Power Transfer from Two-Terminal Network to a Load

For research of the energy transfer from an active two-terminal network to the load we consider the electric circuit in Fig. 3.21.

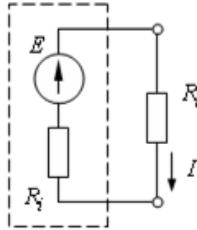

Fig.3.21

We consider, that the parameters of e.m.f. source are invariable, and a load resistance is varied. The current in the electric circuit by Ohm's law, taking into account the series connection of the source and the load:

$$I = \frac{E}{R_i + R_l} . \quad (3.38)$$

The voltage drop inside the voltage source:

$$U_i = R_i I = E \frac{R_i}{R_i + R_l} \quad (3.39)$$

The voltage across output terminals of the source and across the load:

$$U_l = E - U_i = E - E \frac{R_i}{R_i + R_l} = E \frac{R_l}{R_i + R_l} \quad (3.40)$$

The power generated by the e.m.f. source:

$$P = EI = \frac{E^2}{R_i + R_l} \quad (3.41)$$

The power of losses in the e.m.f. source:

$$P_d = I^2 R_i = \frac{E^2 R_i}{(R_i + R_l)^2} \quad (3.42)$$

The power actually dissipated in the load:

$$P_l = I^2 R_l = \frac{E^2 R_l}{(R_i + R_l)^2} \quad (3.43)$$

The efficiency is

$$\eta = \frac{P_l}{P} = \frac{R_l}{R_i + R_l} \quad (3.44)$$

Given equations connect the values which characterize an energy transfer from an energy source to a load.

The most important operating modes of any electric circuit are: *idling (or open circuit), the short circuit, coordinated, and nominal*.

The *idling (or open circuit) rate (o.c.)* is the mode at which the load is disconnected from an energy source ($R_{l_o} \rightarrow \infty$). Then the current in an external circuit is absent $I_o = 0$. Thus, the source does not give energy to the external circuit $P_o = 0$, and load does not consume it $P_{l_o} = 0$. The efficiency in this mode aspires to 1 (if there are no energy losses in a source in the idling mode). From Eq. (3.42) follows, that in this mode the idling voltage across the terminals is equal to the value of e.m.f. ($U_{l_o} = E$).

Short circuit is a condition which appears when source input terminals are short-circuited ($R_{l_k} \rightarrow 0$). Then a short-circuit current in a circuit

is restricted only to an internal source resistance R_i , ($I_k = \frac{E}{R_i}$), that is the

extremely dangerous, as usually this resistance has very little value, and the current in a circuit can reach such a high value at which the source can be put out of action. Therefore, the short circuit rate in the most cases is emergency. But some kinds of the electrotechnical equipment (electroslag remelting furnaces, welding transformers, etc.) work in the rates which are close to a short circuit regime. The voltage across the input source terminals is equal to zero $U_{l_k} = 0$. The power which oscillated by an ideal e.m.f. source attains the maximum value and is completely outlaid for losses in the source: $P_{\max} = P_k = P_{d_k} = \frac{E^2}{R_i}$. The load does not consume the energy $P_{l_k} = 0$. Therefore, the efficiency is equal to zero: $\eta_k = 0$.

The idling and short circuit conditions are the boundary ones.

The *coordinated load regime* is the rate at which the power given out by a source into a load attains the maximum value. It is possible at a certain coordination of parameters of an electric circuit. That is why this rate has such a name. From Eq. (3.45) follows, that at a certain load resistance, the load power reaches a maximum value, as it is equal to zero in short circuit mode ($R_{l_k} = 0$, $I_k = \frac{E}{R_i}$) and idling one ($R_{l_o} \rightarrow \infty$, $I_o = 0$).

On taking derivative $\frac{dP_l}{dR_l}$ and equating it to zero, we will define the value of the load resistance corresponding to a maximum power:

$$\frac{dP_l}{dR_l} = E^2 \frac{(R_i + R_l)^2 - 2R_l(R_i + R_l)}{(R_i + R_l)^4} = E^2 \frac{R_i^2 - R_l^2}{(R_i + R_l)^4} = 0.$$

From this equation we define the value of the load resistance corresponding to a maximum power: $R_l = R_i$. The last condition corresponds to

the current: $I_y = \frac{E}{2R_i} = \frac{I_k}{2}$. The power of the receiver in this mode

reaches a maximum value and is equal to the power of losses inside a

source: $P_{l_y} = P_{l_{\max}} = P_{d_y} = \frac{E^2}{4R_i}$. The power input from the equivalent

generator is $P_y = \frac{E^2}{2R_i}$. As one can see from the received expressions in the

coordinated load mode, the efficiency of a source $\eta_y = 0,5$. In power electrotechnical circuit transferring electric energy of large power one must aspire to provide the greatest possible efficiency. In this case one must observe the condition $R_l \gg R_i$, for what it is necessary either to increase a load resistance or to reduce the internal resistance of a source.

The nominal condition is the mode at which the elements of electric circuit work in the conditions of corresponding to the design. For elements of the circuit the nominal parameters providing a nominal operating mode, are current, voltage and power which are specified in reference books, the engineering specifications or on the element. Usually under a nominal voltage U_{nom} is meant an idling voltage $U_{o.c.}$, instead of the voltage at which a nominal current I_{nom} is provided. Power installations usually work in the modes at which currents and powers do not exceed nominal values, and voltages are close to nominal ones. For more evident representations about the received interrelations of values one can use characteristics - functions in which a current I is used as the argument: $U_l(I_l)$; $U_i(I_l)$; $P(I_l)$; $P_d(I_l)$; $P_l(I_l)$; $\eta(I_l)$. In order to receive the generalized characteristics,

we will express the given values in relative units, using as base-line values - a short circuit current $I_k = \frac{E}{R_i}$ - for a current, the e.m.f. source E - for a

voltage; the maximum power of e.m.f. source $P_{max} = \frac{E^2}{R_i}$ - for power.

As the argument in all functions, it is used the relative value of current $I^* = \frac{I}{I_k} = \frac{E}{R_i + R_l} \cdot \frac{R_i}{E} = \frac{R_i}{R_i + R_l}$. Taking into account the last parity we will receive dimensionless characteristics from equations (3.39) - (3.44).

The voltage drop inside in a source:

$$U_i^* = \frac{U_i}{E} = \frac{R_i}{R_i + R_l} = I^* \quad (3.45)$$

The voltage across output source terminals and across a load:

$$U_l^* = \frac{U_l}{E} = \frac{E - U_i}{E} = 1 - \frac{R_i}{R_i + R_l} = 1 - I^* \quad (3.46)$$

The power generated by an e.m.f. source:

$$P^* = \frac{P}{P_{max}} = \frac{E^2}{R_i + R_l} \cdot \frac{R_i}{E^2} = \frac{R_i}{R_i + R_l} = I^* \quad (3.47)$$

The power of losses inside the source:

$$P_d^* = \frac{P_d}{P_{max}} = \frac{E^2 R_i}{(R_i + R_l)^2} \cdot \frac{R_i}{E^2} = \frac{R_i^2}{(R_i + R_l)^2} = (I^*)^2 \quad (3.48)$$

The power which is consumed by a load (the receiver power):

$$P_l^* = \frac{P_l}{P_{max}} = \frac{E^2 R_l}{(R_i + R_l)^2} \cdot \frac{R_i}{E^2} = \frac{R_i}{R_i + R_l} \cdot \frac{R_l}{R_i + R_l} = I^* (1 - I^*) \quad (3.49)$$

The efficiency of the e.m.f. source:

$$\eta^* = \frac{P_l}{P_{max}} \cdot \frac{P_{max}}{P} = \frac{R_l}{R_i + R_l} = I^* \quad (3.50)$$

The graphs of dependences $U_l^*(I^*)$ and $U_i^*(I^*)$ in the dimensionless form are presented in Fig. 3.22, *a* and the graphs of dependences $P^*(I^*)$, $P_l^*(I^*)$, $U_d^*(I^*)$, $\eta^*(I^*)$ are in Fig. 3.22, *b*.

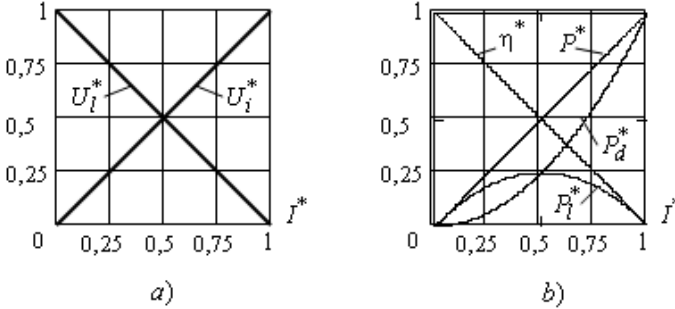

Fig. 3.22. The graphs of dependences

3.15. Energy Relation in Electric Direct Current Circuit

For any electric *dc* circuit, it is possible to make an *energy balance* outflowing from the law of energy conservation: the algebraic sum of all powers which are developed by electric energy sources in a circuit, should be equal to the total sum of the powers which the load converts into other kinds of energy. The energy balance equation has the form:

$$\sum_{p=1}^P E_p I_p + \sum_{q=1}^Q U_{Jq} J_q = \sum_{k=1}^K I_k^2 R_k \quad (3.51)$$

where $\sum_{p=1}^P E_p I_p$ is the power which P e.m.f. sources develop; $\sum_{q=1}^Q U_{Jq} J_q$ is the power which Q current sources develop; U_{Jq} is the voltage across

the terminals of q current source; $\sum_{k=1}^K I_k^2 R_k$ is the power which is diffused

by K load resistances. The power which is converted in the load $I_k^2 R_k$, can accept only positive values as a load (resistance devices) always works in the rate of electric energy consumption. Expressions $E_p I_p$ and $U_{Jq} J_q$ may be both positive (sources work in the rate of energy generation) and negative (sources work in the rate of power consumption).

3.16. The Potential Diagram

A potential diagram is a plot of potential distribution round a circuit, as a function such a circuit resistance.

The sequence of construction of a potential diagram:

- 1) choose any closed mesh with some e.m.f.s and assume a positive direction for summation round that mesh;
- 2) any node of the mesh is earthed i.e. its potential is equal to zero;
- 3) mark every point of the mesh (we must have only one element between two points) and calculate the nodal potentials along the mesh.

If we have an e.m.f. between two points, and its direction coincides with the direction of summation round the mesh, we take it with a plus sign. In the opposite case its sign will be minus. With currents the opposite is true. The coincidence of current direction with the direction of summation round the mesh gives a negative voltage drop, and their mismatch gives a positive voltage drop. One must remember that current always flows from the point with a higher potential to the point with a lower one.

Example 3.9. See Fig. 3.23. $E_1 = 50\text{ V}$, $E_2 = 30\text{ V}$, $J = 1\text{ A}$, $R_1 = 10\ \Omega$, $R_2 = 15\ \Omega$, $R_3 = 20\ \Omega$, $R_4 = 25\ \Omega$, $R_5 = 30\ \Omega$, $R_6 = 35\ \Omega$, draw a potential diagram for a contour with two e.m.f. sources.

Solution: The currents in the branches were found in examples 3.4 – 3.5.

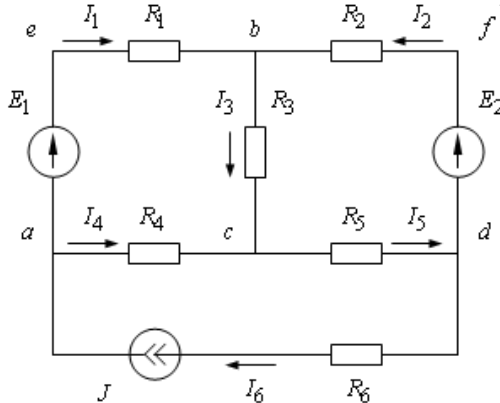

Fig. 3.23

Let's consider mesh $caebfdc$. We choose the junction c to be at zero that is $\varphi_c = 0\text{ V}$. In the diagram of Fig. 3.24 it is the origin of coordinates.

Now we can calculate the potentials of nodes along the outside mesh:

The potential at a is $\varphi_a = \varphi_c + R_4 I_4 = 0 + 25 \cdot (-0,536) = -13,4\text{ V}$.

The potential at e

$$\varphi_e = \varphi_a + E_1 = -13,4 + 50 = 36,6 \text{ V.}$$

The potential at b :

$$\varphi_b = \varphi_e - R_1 I_1 = 36,626 - 10 \cdot 1,536 = 21,24 \text{ V};$$

The potential at f :

$$\varphi_f = \varphi_b + R_2 I_2 = 21,24 + 15 \cdot (-0,471) = 14,18 \text{ V};$$

The potential at d :

$$\varphi_d = \varphi_f - E_2 = 14,18 - 30 = -15,82 \text{ V.}$$

Now we must return to junction c :

$$\varphi_c = \varphi_d + I_5 R_5 = -15,82 + 30 \cdot 0,527 = -0,01 \approx 0 \text{ V.}$$

Hence, the zero result shows that the calculation of nodal potentials for a contour is fulfilled correctly. Further draw the potential diagram. We lay the resistances off an abscissa, and the values of point potentials, as ordinate. All values are put in chosen scale. For each point round a circuit, there is a separate point in the potential diagram.

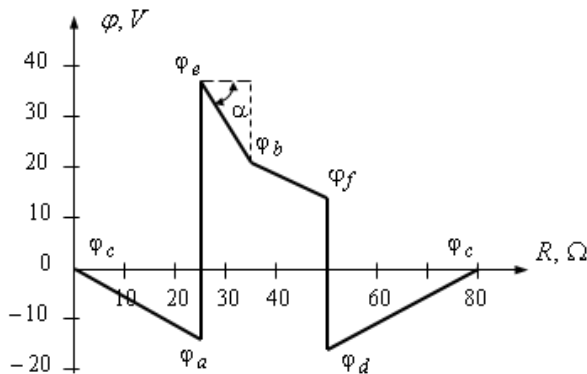

Fig. 3.28. The potential diagram for mesh $caebfdc$.

We have got a sloping line if there is a resistor in this part of the mesh. If we have the e.m.f. source in the part of the mesh there is a perpendicular to y-axis in the diagram. For any contour in the network the potential diagram shows us the change of potentials when we go round the mesh.