

UDC 621.314.21

ESTIMATION OF THE MINIMUM LEVEL OF HIGHER HARMONICS IN THE SINGLE-PHASE-TO-GROUND FAULT CURRENT IN COMPENSATED 6–10 kV NETWORKS

SHAMRAI A. E. postgraduate student of electrical machine department, National university “Zaporizhzhia Polytechnic”, Deputy CEO “Pluton IC” LLC, Zaporizhzhia, Ukraine, ORCID: <https://orcid.org/0009-0007-3516-1989>, e-mail: shamray_andrey@me.com;

ISAIEV I.V. postgraduate student of electrical machine department, National university “Zaporizhzhia Polytechnic”, Head of commercial department “Electra” LLC, Zaporizhzhia, Ukraine, ORCID: <https://orcid.org/0009-0003-5686-4430>, e-mail: isaiev.ihor@gmail.com;

Purpose Development of a model for a compensated 6–10 kV network and a methodology for selecting its element parameters based on estimating the minimum level of higher harmonics in the single-phase-to-ground fault current.

Methodology. To estimate the minimum level of higher harmonics in single-phase-to-ground fault currents, a generalized model of a compensated 6–10 kV cable network and its constituent elements, implemented in the Matlab system with the Simulink extension package, was used. The generalized model of the compensated 6–10 kV cable network and its element parameters were obtained based on a statistical analysis of data from the power supply systems of cities and industrial enterprises.

Findings. The main requirements for the equivalent calculation scheme of a 6–10 kV cable network for estimating the minimum level of higher harmonics in the single-phase-to-ground fault current were formulated, and the ranges of variation and average values of its parameters were determined. The developed mathematical model of the 6–10 kV cable network accounts for the main factors determining the minimum level of higher harmonics in the single-phase-to-ground fault current. Based on the results of computational experiments performed on the mathematical models of 6–10 kV cable networks, it was established that to ensure the required sensitivity, single-phase-to-ground fault protection devices based on the use of higher harmonics must have a primary pickup current of no more than 0.1A.

Originality. A model of a compensated 6–10 kV network was developed, which allows clarifying the sensitivity requirements for single-phase-to-ground fault protection systems based on the use of higher harmonics, thereby enhancing their operational efficiency.

Practical value. Based on the mathematical model, a methodology for selecting its element parameters is proposed, which utilizes the estimation of the minimum level of higher harmonics in the single-phase-to-ground fault currents.

Keywords: compensated network; mathematical model; transformer; higher harmonics protection.

I. INTRODUCTION

In distribution cable networks with a voltage of 6–10 kV in industrial and urban power supply, which typically operate with resonant neutral grounding via an arc-suppression reactor (capacitive current compensation), single-phase-to-ground faults are the main type of damage [1], [2]. Therefore, the reliability of such networks and the power supply to consumers depends on the technical perfection of single-phase-to-ground faults protection. In compensated 6–10 kV cable networks, the primary application for single-phase-to-ground faults protection is devices based on the use of absolute and relative measurement methods for higher harmonics in the zero-sequence currents of the protected object's connections [3]-[5]. The application of directional protection devices based on monitoring the direction of zero-sequence power of higher harmonics (for example, [6]) is also considered promis-

ing.

II. ANALYSIS OF LAST RESEARCHES

The spectrum of higher harmonics in the voltages and, consequently, in the single-phase-to-ground fault currents of the networks under consideration is unstable and depends on the composition of the higher harmonic sources and their operating modes [7]-[9].

The primary sources of higher harmonic in 6–10 kV networks are thyristor (or valve) converters [10], and in their absence in the consumer load, they are the power transformers of the receiving substations (6–10/0.4 kV) [11], [12]. The most pronounced harmonics in the spectrum of these sources are the 5th, 7th, 11th, and 13th harmonics [13], [14]. To ensure stable functioning under conditions of higher harmonics spectrum instability, protection devices are designed to respond to the total level

(typically the root-mean-square (RMS) value) of these harmonics. Therefore, when developing and designing higher harmonic -based protection, it becomes necessary to estimate the minimum possible total higher harmonics level in the single-phase-to-ground fault current for the networks under consideration at various values of the total capacitive current to determine the requirements for their sensitivity to the primary current and the scope of possible application. Estimates of the minimum higher harmonics level in the single-phase-to-ground fault current of compensated 6–10 kV cable networks were previously provided in the works [15], [16]. These estimates were conducted in the late 1960s based on simplified analytical methods and models of 6–10 kV cable networks and their elements, which limited the capabilities of researchers and developers. Operating experience does not always confirm the sensitivity and potential application scope of higher harmonics -based protection systems, as estimated by those studies (for example, [17]). Therefore, refining the sensitivity requirements for higher harmonics -based single-phase-to-ground fault protection is considered a pressing issue [18]-[20].

The emergence of modern simulation systems for electric power systems (EPS) and power engineering facilities, such as the Matlab system with the Simulink extension package, provides the opportunity to use more complex and, consequently, more accurate models of compensated 6–10 kV networks to refine the minimum higher harmonics level in SPGF currents and the resulting sensitivity requirements for the protection systems based on them.

III. FORMULATION OF THE WORK PURPOSE

Development of a model for a compensated 6–10 kV network and a methodology for selecting its element parameters based on estimating the minimum level of higher harmonics in the single-phase-to-ground fault current.

IV. EXPOUNDING THE MAIN MATERIAL AND RESULTS ANALYSIS

The harmonic content of the fault current at the point of the single-phase-to-ground fault and the zero-sequence currents (3I₀) of the faulted and unfaulted connections is determined with sufficient accuracy by the harmonic content of the voltage of the faulted phase at the point of the ground fault [5], [8]. When determining the minimum level of higher harmonics in the phase voltages of the network and, consequently, in the single-phase-to-ground fault current, it is assumed in [5] that the EMF of the power source is purely sinusoidal (the total harmonic distortion coefficient KTHD = 0), and the main source of higher harmonics is the non-linearity of the magnetization curve of the 6–10/0.4 kV transformers installed at the receiving transformer substations (TS) or distribution transformer substations (DTS) of 6–10 kV cable networks in industrial or urban power supply. This assumption is acceptable for industrial consumers with a shift-based daily schedule, where during the night-time load drop or

on weekends, all major technological installations, and consequently, the main higher harmonics sources (primarily thyristor/valve converters), except for the transformers, can be almost completely switched off. Theoretical information must expand, and not repeat, stated in the introduction and review of literature information.

In [5], the equivalent circuit of the network shown in Fig.1, a is used to estimate the minimum level of higher harmonics in the single-phase-to-ground fault current.

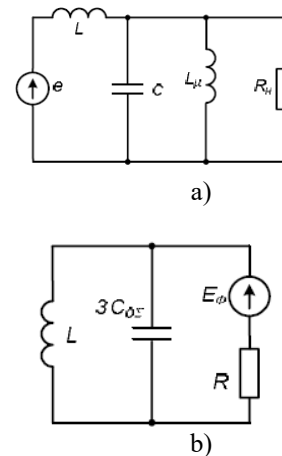

Figure 1. Calculated equivalent circuits of the 6–10 kV network for estimating the minimum higher harmonics level

In the equivalent circuit according to Fig. 1, $C = 3C_{0\Sigma}$ is the total capacitance of the three phases of the network to ground; e is the equivalent EMF of the power source; L is the total inductance of the supply transformers of the power center (PC); L_{μ} is the total inductance of the magnetization branches of all connected load transformers; R_n is the total load resistance of the transformers.

For the purpose of simplification, the calculated equivalent circuit (Fig. 1, a) does not take into account the influence of several factors on the voltage higher harmonics level at the point of the single-phase-to-ground fault: resistances of the lines connecting the Power Center (PC) to the receiving substations; system impedance; winding resistances of the load transformers; interphase capacitances of the network; complex nature of the load impedance; differences in magnetization currents for transformers of different ratings; the arc-suppression reactor (ASR), and others.

The minimum higher harmonics level, determined by the equivalent circuit in Fig. 1, a, is significantly influenced by the ratio of the ratings of the supply and receiving transformers,

$$S = \frac{S_{sup\Sigma}}{S_{rec\Sigma}}, \quad (1)$$

which was assumed in [5] to be $S = 1.5$ to 3. The minimum level obtained in [5] using the equivalent circuit in Fig. 1, a, for one of the most pronounced harmonics—the 5th harmonic—which primarily determines the sensitivity of higher harmonics -based protection under the conditions considered, is $\approx 2.6\%$ of $I_{c\Sigma}$ when the parameter $S = 1.5$. The corresponding current values for the 5th harmonic for networks with various $I_{c\Sigma}$ values are presented in Tab. 1.

Table 1. Calculated values of the 5th harmonic current $I_5 = 0.26I_{c\Sigma}$

Calculated values of the 5th harmonic current $I_5 = 0.26I_{c\Sigma}$ Current I_5	Value of the 5th Harmonic Current I_5 , A			
	$I_{c\Sigma} = 25A$	$I_{c\Sigma} = 50A$	$I_{c\Sigma} = 100A$	$I_{c\Sigma} = 250A$
In the single-phase-to-ground fault current	0.65	1.3	2.6	6.5
In the zero-sequence current $3I_0$ faulted connection	0.585	1.17	2.34	5.85
The pickup current (or operating current)	0.95	1.4	2.5	4.85

In [8], it is shown that the selectivity and sensitivity conditions for instantaneous overcurrent protection (maximum current protection) based on absolute measurement of higher harmonics can only be ensured on connections (feeders) with relatively small values of their own capacitive current:

$$I_{c_own}^* = \frac{I_{c_own}}{I_{c\Sigma}} \leq 0.1. \tag{2}$$

At values of $I_{c_own}^* = 0.1$, the 5th harmonic current I_5 in the faulted connection will be equal to 0.9 of the I_5 value at the point of the single-phase-to-ground fault (Tab. 1). For comparison with the 5th harmonic current in the faulted connection with $I_{c_own}^* = 0.1$, Tab. 1 also provides the pickup current values for the 5th harmonic for the USZ-2/2 type current protection device, which is the most widely used in compensated 6–10 kV networks [1], [2].

An analysis of the data in Tab. 1 shows that, given the minimum calculated level of the 5th harmonic obtained in [5], the required sensitivity (minimum sensitivity factor $K_{min} \geq 1.5$) of the USZ-2/2 type protection is not ensured (or: is not provided).

In [6], a calculation method for determining the

higher harmonics of the single-phase-to-ground fault current in 6–10 kV cable networks of industrial power supply systems are proposed. The equivalent circuit shown in Fig. 1, b is used to calculate the k -th harmonic in the single-phase-to-ground fault current. In the equivalent circuit of Fig. 1, b, as in the equivalent circuit of Fig. 1, a, several factors that can significantly influence the higher harmonics level in the single-phase-to-ground fault current are not taken into account, namely: the resistance of the lines connecting the power center (PC) to the receiving substations; interphase capacitances; the ratios between the network capacitances at the ends of the lines; the winding resistances and the load of the transformers; the arc-suppression reactor (ASR); and others.

To determine the equivalent EMF of the E_V , [6] utilizes data on the harmonics of transformer magnetization currents [9]. Calculations performed in [6] using the average values of E_V transformers and the parameters of other elements in the equivalent circuit shown in Fig. 1, b yielded the following levels for the 3rd, 5th, and 7th harmonics in the SPGF current: $I_3 \approx 0.1A$, $I_5 \approx 0.75A$, $I_{11} \approx 0.62A$ for a 6 kV network with $I_{c\Sigma} = 40A$ and a parameter value of $S = 0.75$. If it is assumed that the percentage ratio of the fundamental (1st) and higher harmonics does not change with a change in the total network capacitive current $I_{c\Sigma} = 25A$, the calculated value $I_5 \approx 0.47A$. This value is noticeably lower than the one obtained in [5] (Table 1).

The calculated data obtained in [5], [6] show that the higher harmonic level in single-phase-to-ground fault (SPGF) currents can be small. Therefore, inaccuracies (or errors) in the models of the 6–10 kV network and its constituent elements can lead to imprecise conclusions when assessing the sensitivity requirements for higher harmonics -based SPGF protection and the conditions for their applicability. The use of modern simulation systems, such as Matlab, makes it possible to create more accurate models of 6–10 kV networks for calculating higher harmonics in single-phase-to-ground fault currents and to obtain more precise estimates of the minimum higher harmonics level in single-phase-to-ground fault currents in compensated 6–10 kV cable networks, which determine the requirements for protection against this type of fault based on higher harmonics.

The influence of the accuracy of the magnetization curve approximation on the assessment of the higher harmonic spectrum generated by transformers.

In calculating the higher harmonics generated by power transformers, [5] assumes that the magnetization curve of the transformers is approximated with acceptable accuracy by a fifth-degree polynomial:

$$i_\mu \approx \alpha \cdot \psi^5. \tag{3}$$

Fig.2 shows, for comparison, the magnetization

characteristic of E330 steel, which is widely used for manufacturing the magnetic cores of power transformers, and its approximation by a fifth-degree polynomial.

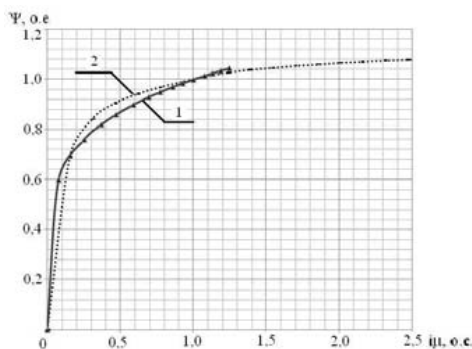

1 – initial curve; 2 – approximation by a fifth-degree polynomial

Figure 2. Magnetization curves of E330 Steel (in p.u.)

An analysis of the obtained data (Fig. 2) shows that the approximation of the magnetization curve for electrical steel used in [5] can lead to noticeable errors compared to the actual curve and, consequently, to errors in estimating the harmonics of the magnetizing current. An assessment of these errors was performed using models of transformers with a non-linear magnetic core, developed in the Matlab system. The first model used the real magnetization curve of E330 steel, while the second used its approximation by a fifth-degree polynomial. A comparison of the simulation results showed that replacing the real magnetization characteristic with its approximation by a fifth-degree polynomial yields an error in estimating the level of the 5th harmonic of up to 10% or more, and for the 7th harmonic, up to 40% or more (Figure 3).

Calculations using models of 6–10/0.4 kV transformers with the real magnetization characteristic for electrical steels E42 and E330 also showed that the average ratios of the root-mean-square (RMS) values of the 5th and 7th harmonics to the total magnetizing current are within the following ranges: $I_{5*} = 0.086 - 0.154$ and $I_{7*} = 0.024 - 0.053$. For comparison, it can be noted that when assessing the minimum level of higher harmonics generated by transformers, [6] assumed these ratios to be $I_{5*} = 0.22$ and $I_{7*} = 0.1$.

Model analysis showed that the greatest accuracy in estimating the higher harmonics generated by transformers is provided by approximating their magnetization curve with an arc-tangent function (fig. 4):

$$B = \alpha \cdot \text{arctg}(\beta H) + \gamma H^m \quad (4)$$

Taking into account the obtained results, models were developed in the Matlab simulation environment for all major types of 6–10/0.4 kV transformers at receiving substations, ranging in power from 630 to 10,000 kVA with winding connection schemes Y/Δ-11 and Y/Y-0, as

well as for the 110–220/6–10 kV supply transformers, ranging in power from 25 to 100 MVA, installed at the power centers of the 6–10 kV cable networks.

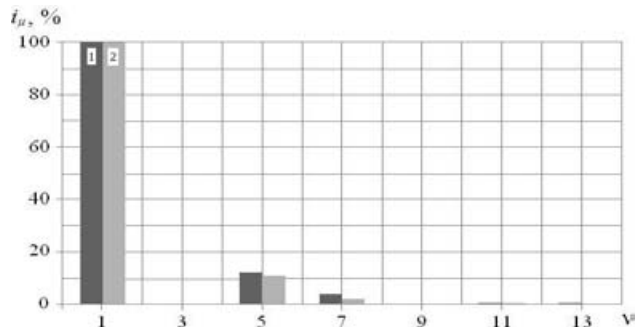

1 – model using the real magnetization curve of E330 steel; 2 – model using the approximation of the E330 steel magnetization curve by a fifth-degree polynomial

Figure 3. Magnetizing current spectrums obtained from transformer models in the Matlab system at $U = U_{nom}$

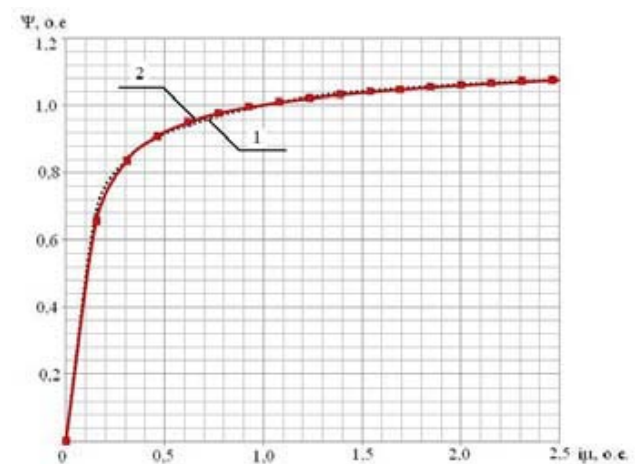

1 – real magnetization curve; 2 – approximation by an arc-tangent function

Figure 4. Magnetization curves of E330 Steel

The Influence of higher harmonics generated by arc-suppression reactors.

In calculations of higher harmonics in single-phase-to-ground fault currents, it is often assumed (e.g., in [5, 6]) that the arc-suppression reactor is not a significant source of higher harmonics because it has a practically linear magnetization characteristic across the entire range of compensation current regulation. However, experimental data, provided, for example, in [10], [11], show that the degree of linearity of the ASR's voltage-ampere characteristic (magnetization characteristic) significantly depends on its operating mode. Therefore, the level of higher harmonics generated by the ASR will vary depending on the operating mode of the arc-suppression reactor.

The highest degree of non-linearity in the voltage-ampere characteristics (magnetization characteristics) and, consequently, the highest level of generated harmon-

ics for step-regulated ASRs [11] occurs when operating in modes with maximum values of voltage and compensation current (Fig. 5).

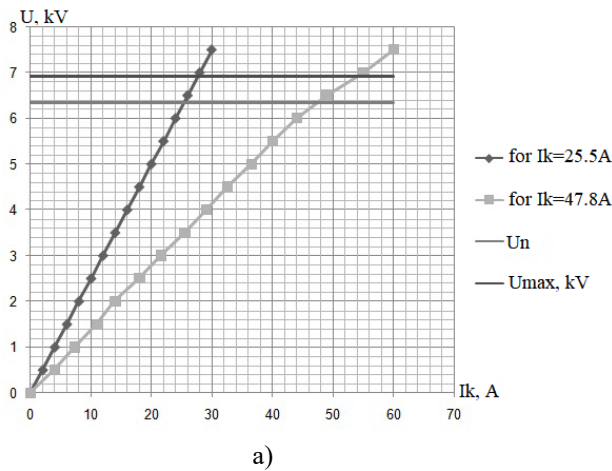

a)

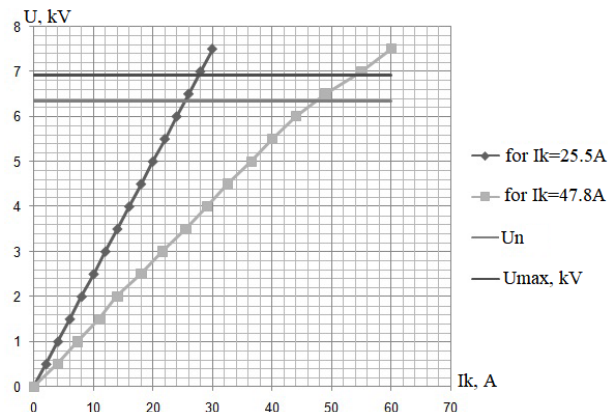

b)

a – for a continuously regulated reactor of RZDPOM type; b – for a step-regulated reactor of ZROM type

Figure 5. Voltage-ampere characteristics of arc-suppression reactors

The results of calculations for the harmonics generated by plunger-type and step-type arc-suppression reactors, performed using models with the magnetization curve approximated by equation (1) for various levels of operating voltage on the ASR and the maximum compensation current, are presented in Table 2

Table 2. Calculated values of higher harmonics generated by ASR at various levels of operating voltage and maximum compensation current

Harmonic number, ν	$I_{\nu,m}, \% \text{ at } U_{sc}$		
	$0.9U_{f,n}$	$U_{f,n}$	$1.1U_{f,n}$
1	100	100	100
3	0.655	1.097	1.888
5	0.157	0.294	0.565
7	0.009	0.042	0.109

An analysis of the data in Table 2 shows that, in contrast to other sources of higher harmonics in 6–10 kV networks (thyristor converters, transformers, etc.), the 3rd harmonic is the most pronounced in the higher harmonics spectrum generated by the arc-suppression reactor. The total level of significant harmonics (3rd, 5th, and 7th) generated by the arc-suppression reactor in the operating mode under consideration is approximately 1.13%.

Model analysis of the ASR also showed that when the ASR operates with compensation currents lower than the limit (rated) current, the degree of linearity of the voltage-ampere characteristics significantly increases, and the level of harmonics generated by the reactor sharply decreases. Specifically, for step-regulated ASRs operating with $I_{tap,nom}$ or for continuously regulated (plunger-type) ASRs operating with minimum compensation current, the level of harmonics they generate, as the model analysis showed, is practically zero. Given that such ASR operating modes are possible in service, the ASR can be excluded from the 6–10 kV network calculation scheme when assessing the minimum level of Higher Harmonics in the Single-Phase-to-Ground Fault current.

Considering the above, the calculation model of a compensated 6–10 kV cable network should take into account the following main factors influencing the minimum level of higher harmonics in the single-phase-to-ground fault current: short-circuit power at the system buses; rating (power) and parameters of the supply transformer installed at the power center; the varying number of transformers of different ratings installed at the receiving substations, which generally have different parameters (magnetizing current I_{μ} in p.u., short-circuit voltage

U_{sc} , etc.); The difference in coupling impedances between the RS (lengths and total cross-section of the cable lines); the loads of the receiving transformers. In a generalized form, the calculation scheme for a 6–10 kV network, which takes into account the influence of these main factors, can be presented as shown in Figure 6.

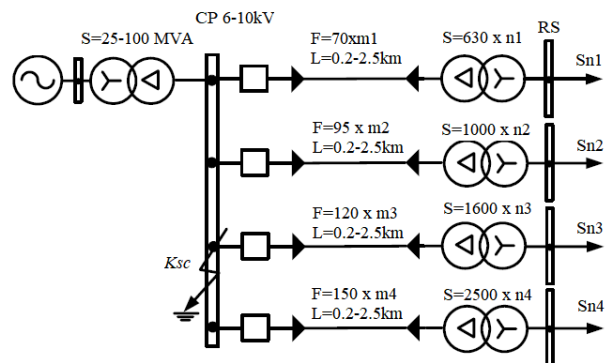

Figure 6. Generalized 6–10 kV network diagram for estimating the minimum level of higher harmonics in the single-phase-to-ground fault current

The parameters of the elements in the calculation scheme (Fig. 6) and their ranges of variation were determined based on a statistical analysis of data from 6–10 kV cable networks of power supply systems for enterprises across a range of industries (metallurgical, oil refining, pulp and paper) and urban power supply systems (Table 3)

Table 3. Parameters of the elements of the calculation scheme for estimating the minimum level of higher harmonics in the single-phase-to-ground fault current

$I_{c\Sigma}$, A	$I_{k.sup}^{(3)}$, kA	$S_{sup.tr}$, MVA	L , km	L_{subs} , km	S , p.u.
20-100	20-40	25-100	0.3-2.5	0.8	0.7-1.5

Table 3 lists the values of the following parameters of the elements in the calculation scheme $I_{c\Sigma}$ is the total capacitive current of the network; $I_{k.sup}^{(3)}$ is the values of the three-phase short-circuit current at the buses of the supply system; $S_{sup.tr}$ is the rating (power) of the supply transformer installed at the power center; L_{subs} – the length of the cable lines (CL) connecting the PC with the receiving substations; S is the ratio of the power of the supply transformer to the total power of the receiving substation transformers.

Table 4 shows the distribution by the rating (or magnitude of unit capacity) of the transformers installed at the receiving substations.

Table 4. Share of transformers of various unit ratings in the network and the magnitudes of cross-sections of communication lines between the power center and receiving substations

Parameter	for transformer with rated power, kVA"			
	630	1000	1600	2500
Share in the total power of load transformers, %	25	64	7	4
Average cross-section of the cable line from the power center to the TS (DTS), mm ²	70	95	120	150

Results of calculations for harmonic levels during single-phase-to-ground fault on a 6–10 kV cable network model. The mathematical model of the 6–10 kV cable network for the calculation scheme shown in Fig. 6 was realized in the Matlab system environment.

Based on calculations performed on the model, the

minimum levels of the 5th harmonic (which mainly determines the overall minimum level of higher harmonics in single-phase-to-ground fault currents) were determined for compensated 6–10 kV networks for various values of the total network capacitive current $I_{c\Sigma}$ and the parameter S (1).

Table 5 also provides, for comparison, the pickup current values of the USZ-2/2 device and the calculated estimates of the minimum level of the 5th harmonic in the single-phase-to-ground fault current [5], [6].

Table 5. Calculated Values of the 5th harmonic in the single-phase-to-ground fault current

5th harmonic current at the single-phase-to-ground fault location	Current value I_5 , A			
	$I_{c\Sigma}$ =25A	$I_{c\Sigma}$ =50A	$I_{c\Sigma}$ =100A	$I_{c\Sigma}$ =250A
Calculation for S=0.7	0.2-0.23	0.56-0.65	1.55-1.78	4.73-5.44
Calculation for S=1.5	0.33-0.38	0.88-0.98	2.43-2.67	6.46-7.11
Calculation for S=1.5, according [5]	0.65	1.3	2.6	6.5
Calculation for S=0.75, according [6]	0.47	0.94	1.88	4.7
Operating current USZ-2/2	0.95	1.4	2.5	4.85

The minimum level of higher harmonics was determined for the minimum operating voltage value in the network $U_{op}=0.95U_{nom}$. During the calculations, the parameters of the network elements were varied within the limits presented in table 3 and table 4.

An analysis of the data presented in Table 5 shows that the estimated minimum levels of higher harmonics (in single-phase-to-ground fault currents for compensated networks, obtained from model calculations, are 2–3 times lower than similar estimates obtained in [5], [6], and 3–4 times lower than the minimum pickup current of current-based single-phase-to-ground fault protection devices using higher harmonics, such as the USZ-2/2.

For single-phase-to-ground fault protection based on higher harmonics, a sensitivity factor of no less than 2–2.5 is recommended [8]. To ensure this level of sensitivity in operating modes of 6–10 kV cable networks where the higher harmonics level is minimal, the minimum primary pickup current of existing and developing single-phase-to-ground fault protection devices based on higher harmonics should be reduced to values of approximately 0.1 A.

V. CONCLUSION

The main requirements for the equivalent calculation scheme of a 6–10 kV cable network for estimating the minimum level of higher harmonics in the single-phase-to-ground fault current were formulated, and the ranges of variation and average values of its parameters were determined.

The developed mathematical model of the 6–10 kV cable network takes into account the main factors determining the minimum level of higher harmonics in the single-phase-to-ground fault current.

Based on the results of computational experiments performed on mathematical models of 6–10 kV cable networks, it was established that to ensure the required sensitivity, single-phase-to-ground fault protection devices based on the use of higher harmonics must have a primary pickup current of no more than 0.1 A.

REFERENCE

- [1] Abolhasani, A., Vahidi, B., & Shariatzadeh, H. (2019). An Adaptive Earth Fault Protection Scheme for Compensated Medium-Voltage Distribution Networks. *IEEE Transactions on Power Delivery*, 34(3), 1146–1155.
- [2] Goyal, S., & Sharaf, A. M. (2017). A Comprehensive Review of Earth Fault Detection and Location Techniques in Compensated Distribution Networks. *Electric Power Systems Research*, 149, 239–251.
- [3] Saleh, S. A., & Badr, H. S. (2016). Directional Earth Fault Protection Using Third Harmonic Components in Compensated Power Networks. *IET Generation, Transmission & Distribution*, 10(15), 3848–3857.
- [4] Panić, S., Vasić, P., & Pezo, M. (2019). Analytic Modeling of Magnetic Saturation and Hysteresis Using Arctangent Functions for Power Transformer Transient Analysis. *Journal of Electrical Engineering*, 70(1), 16–25.
- [5] Vaz, N., & Soares, M. (2022). Harmonic Analysis in Power Systems: The Impact of Transformer Core Saturation Modeled with Analytical Functions. *International Transactions on Electrical Energy Systems*, 32(4), e13256.
- [6] Jha, R. K., & Dash, P. K. (2018). Modeling and Harmonic Analysis of Magnetizing Inrush Current in Power Transformers. *IET Power Electronics*, 11(13), 2097–2106.
- [7] Guo, Y., & Dong, Y. (2015). Analysis of Harmonic Characteristics of Arc-Suppression Coil Grounding Systems and Its Influence on Relay Protection. *Electric Power Systems Research*, 126, 18–24.
- [8] Popov, E. G., & Novikov, L. A. (2020). The Influence of Arc-Suppression Coil Non-linearity on the Third Harmonic Zero-Sequence Current in Medium Voltage Networks. *E3S Web of Conferences*, 178, 01025.
- [9] Wade, G. S., & Brown, P. E. (2016). Petersen Coil Design and Harmonic Performance: Minimizing Higher Harmonics in Compensated Networks. *IEEE Transactions on Industry Applications*, 52(5), 3740–3747.
- [10] Saleh, A. E., & El-Kholy, M. A. (2023). Effect of Voltage Unbalance on the Dynamic Performance of Squirrel-Cage Induction Motor Drive: A Simulation and Experimental Study. *Alexandria Engineering Journal*, 62(2), 527–540.
- [11] Al-Ani, R. O., & Al-Tameemi, I. M. (2018). Virtual Test Bench Development for Induction Motor Performance Analysis under Voltage Unbalance Conditions. *International Journal of Power Electronics and Drive Systems*, 9(3), 1335–1345.
- [12] IEC 60255-151: Requirements for Functional and Performance Standards for Earth Fault Protection in Power Systems.
- [13] IEEE C37.90.1: IEEE Standard for Surge Withstand Capability (SWC) Tests for Protective Relays.
- [14] Mahfouz, S. E., & Abuelnasr, H. A. (2017). A novel method for estimating harmonic distortion in medium voltage distribution networks. *International Journal of Electrical Power & Energy Systems*, 93, 21–29.
- [15] Wojciechowski, J., & Kacek, A. (2020). Assessment of minimum harmonic current level in resonant grounded medium voltage networks for relay protection settings. *Energies*, 13(12), 3165.
- [16] Toma, R., Popescu, M., & Boicea, V. A. (2018). Nonlinear modeling of power transformer magnetization characteristics using analytical functions for transient analysis. *IEEE Transactions on Magnetics*, 54(11), 1–8.
- [17] Sadeghian, M. S., & Ghasemi, S. (2017). Investigation of the harmonic current contribution from arc suppression coils during single-phase-to-ground faults. *Electric Power Systems Research*, 142, 198–205.
- [18] Chen, M., Zhang, B., & Wang, Y. (2020). A novel analytical model for the single-phase-to-ground fault current considering the non-linearity of Petersen coil. *International Journal of Electrical Power & Energy Systems*, 116, 105572.
- [19] Luo, C., Wang, Z., & Li, R. (2022). Sensitivity improvement of high-impedance ground fault protection based on transient zero-sequence current in compensated networks. *IEEE Access*, 10, 70908–70917.
- [20] Abolhasani, A., Vahidi, B., & Shariatzadeh, H. (2019). An adaptive earth fault protection scheme for compensated medium-voltage distribution networks. *IEEE Transactions on Power Delivery*, 34(3), 1146–1155.

Received 02.10.2025;

Accepted 14.11.2025;

Published 26.12.2025;

ОЦІНКА МІНІМАЛЬНОГО РІВНЯ ВИЩИХ ГАРМОНІК СТРУМУ ОДНОФАЗНОГО ЗАМИКАННЯ НА ЗЕМЛЮ У КОМПЕНСОВАНИХ МЕРЕЖАХ 6-10 КВ

ШАМРАЙ А.Є. аспірант кафедри електричних машин НУ «Запорізька політехніка», заступник Генерального директора ТОВ «Плутон ІС», Запоріжжя, Україна, ORCID: <https://orcid.org/0009-0007-3516-1989>, e-mail: shamray_andrey@me.com ;

ІСАЄВ І.В. аспірант кафедри електричних машин НУ «Запорізька політехніка», начальник комерційного відділу ТОВ «Електра», м.Запоріжжя, Україна, ORCID: <https://orcid.org/0009-0003-5686-4430>, e-mail: isaiev.ihor@gmail.com ;

Мета роботи. розробка моделі компенсованої мережі 6–10 кВ, а також методики вибору параметрів її елементів на основі оцінки мінімального рівня найвищих гармонік струму однофазного замикання на землю.

Методи дослідження. Для оцінки мінімального рівня вищих гармонік у струмах однофазного замикання на землю використовувалася узагальнена модель компенсованої кабельної мережі 6–10 кВ та її елементів у системі Matlab з пакетом розширення Simulink. Узагальнена модель компенсованої кабельної мережі 6–10 кВ та параметри її елементів отримано на основі статистичного аналізу даних щодо систем електропостачання міст та промислових підприємств.

Отримані результати. Сформульовано основні вимоги до розрахункової схеми заміщення кабельної мережі 6–10 кВ для оцінки мінімального рівня вищих гармонік струму при однофазному замиканні на землю, визначено діапазони зміни та середні значення її параметрів. Розроблена математична модель кабельної мережі 6–10 кВ враховує основні фактори, що визначають мінімальний рівень вищих гармонік струму однофазного замикання на землю. На основі результатів обчислювальних експериментів, виконаних на математичних моделях кабельних мереж 6–10 кВ, встановлено, що для забезпечення необхідної чутливості пристрою захисту від однофазного замикання на землю, що ґрунтуються на використанні вищих гармонік, повинні мати первинний струм спрацьовування не більше 0,1 А.

Наукова новизна. Розроблено модель компенсованої мережі 6–10 кВ, яка дозволяє уточнити вимоги до чутливості захисту від однофазного замикання на землю, заснованих на використанні вищих гармонік, та підвищити ефективність їх функціонування.

Практична цінність. На основі математичної моделі запропоновано методику вибору параметрів її елементів на основі оцінки мінімального рівня вищих гармонік у струмах однофазного замикання на землю.

Ключові слова: компенсована мережа; математична модель; трансформатор; захист від вищих гармонік.